

A computational intelligence-based technique for the installation of multi-type FACTS devices

Winnie Chong Mei Yen^a, Mohd Helmi Mansor^{a,*}, Sharifah Azwa Shaaya^a, Ismail Musirin^b

^aDepartment of Electrical and Electronics Engineering, College of Engineering, Universiti Tenaga Nasional, Malaysia.

^bSchool of Electrical Engineering, College of Engineering, Universiti Teknologi MARA, Selangor, Malaysia.

(Communicated by Madjid Eshaghi Gordji)

Abstract

As power demand rises, the power system becomes more stressed, potentially leading to an increase in power losses. When compared to lower power losses, higher power losses result in higher power system operating cost. Flexible AC Transmission System (FACTS) devices help to reduce power losses. This paper describes the use of a computational intelligence-based technique, in this case the Artificial Immune System (AIS), to solve the installation of Thyristor Controlled Static Compensator (TCSC) and Static VAR Compensator (SVC) in a power system while ensuring optimal sizing of both devices. The goal of determining the best locations and sizes for the multi-type FACTS devices is to minimize system power loss. Three case studies are presented to investigate the effectiveness of the proposed AIS optimization technique in solving the multi-type FACTS device installation problem under various power system conditions. The optimization results generated by the proposed AIS are beneficial in improving the power system, particularly in terms of system power loss minimization, which also contributes to power system operating cost minimization. As a result, the likelihood of this being sustainable and able to be implemented for an extended period is greater.

Keywords: FACTS devices, Computational intelligence, Artificial immune system, Loss minimization and multi-type

1. Introduction

The evolution of power system stability today has evolved in response to power demand, as existing transmission lines are unable to support due to limited resources [7, 19]. Because of the

*Corresponding author

Email addresses: winniechg98@gmail.com (Winnie Chong Mei Yen), mhelmi@uniten.edu.my (Mohd Helmi Mansor), shazwa@uniten.edu.my (Sharifah Azwa Shaaya), ismailbm1@uitm.edu.my (Ismail Musirin)

Received: June 2021 *Accepted:* September 2021

limited resources, there was a risk that as the transmission lines became increasingly loaded, they would create a power transfer-limiting factor [19, 18, 2]. By also including the fact that, in order to expand a power transmission network, obstacles such as environmental, cost, and stability issues were managed to shut down [12, 17]. As a result, the Flexible AC Transmission Systems (FACTS) controller has been widely used in the problem-solving of steady-state control of a power system.

The FACTS device is a combination of power electronics components and traditional power system components that can increase a line's power transfer while also effectively assisting in the operation of the power system within a safe margin of stability [5, 9]. FACTS controllers can perform network condition control in a short period of time, and this feature of FACTS devices can be used to improve the voltage stability, steady state stability, and transient stability of a dynamic power system. This FACTS feature contributes to the increased use of an existing network in close proximity to its thermal loading capacity, lowering the likelihood of replacing transmission lines [21, 26]. Furthermore, FACTS devices monitor the network's power flow while reducing the heavy load on the lines, resulting in increased load capability, reduced power system losses, improved network reliability, lower production costs, and compliance with contractual requirements.

The FACTS devices are classified into three types based on their switching mode: mechanically switched (such as phase shifting transformers), thyristor switched, or fast switched (which uses an Insulated-Gate Bipolar Transistors (IGBTs). Others, such as the Phase Shifting Transformer (PST) and the Static VAR Compensator (SVC), have been recognized because they are the first generation of FACTS devices capable of controlling voltage at the necessary bus to improve the voltage profile of the power system. Because of recent advances in power electronics and controls, the application range of FACTS has expanded [19, 21].

There has been a variety of advances in the fields of computational intelligence research over the year, with the most popular types of research being population-based, stochastic search algorithms with collaborative and competitive traits. Kennedy and Eberhart [16] developed the Particle Swarm Optimization (PSO) algorithm, which is based on the social patterns of animal swarms (for example, bird blocks and fish schools). Furthermore, population-based computational intelligence techniques such as Particle Swarm Optimization (PSO), Evolutionary Programming (EP), and Genetic Algorithm (GA) were used to evaluate the overall loadability of the transmission system after the installation of FACTS devices [22]. Meanwhile, other techniques such as Artificial Neural Network (ANN), Simulated Annealing (SA), Ant Colony Optimization (ACO), and Artificial Immune System (AIS) are being used more frequently for purposes other than power system stability. EP, Hybrid Tabu Search and Simulated Annealing (TS/SA), GA, Repetitive Power Flow (RPF) process, and Fuzzy Decision Making, as well as PSO, were used to test the optimal placement of various types of FACTS devices in the power system. The GA and PSO techniques were used as an additional aspect to improve the TCSC parameters. Even though both techniques are effective, PSO has an advantage over GA in terms of a more robust balance mechanism and greater variance in both local and broad-ranging abilities. The PSO and EP techniques were implemented on the IEEE 30-Bus RTS, demonstrating their efficacy in loss minimization schemes [4, 15]. The computational intelligence techniques for multi-FACTS device installation face challenges when it comes to implementing the entire system. The technique has been used for various types of devices in recent years, but constraints have limited the number of multi-FACTS that can be installed. The aforementioned obstacles were supposed to be overcome in order to produce a high-efficiency system. Based on previous research, studies were conducted to improve transmission system loadability, reduce installation costs, or both by determining the best placement and control of FACTS devices using a variety of methods. The cost must be accurately planned so that the product (system) does not cost more than the total initial cost. This increases the likelihood of the product (system) being confirmed as a

sustainable system and being implemented for an extended period. Nonetheless, fewer studies on the computational time and convergence characteristics of loadability enhancement using the approach described in the preceding introduction have been conducted. The computational time usually increases as the scale of the optimization problem grows larger; however, it is claimed that it only takes a short period of time for computation to maintain high performance.

The primary goal of this paper is to use AIS, a computational intelligence-based technique, to optimize the installation of multi-FACTS devices in power systems. The technique is expected to be able to reduce existing disadvantages and reduce system power loss in the power system to improve its operation.

2. Research method

This section discusses the development of the AIS optimization technique for installing multi-FACTS devices including the Static VAR Compensator (SVC) and Thyristor-Controlled Series Compensator (TCSC) on the IEEE 26-Bus RTS. The TCSC and the SVC are the two types of FACTS devices that have been selected for installation in this project, and they will be used together. These FACTS devices have been chosen based on their characteristics in terms of assisting in the reduction of the system’s power loss, among other things. TCSC allows for the control and advancement of transmission line power transfer capabilities by adjusting the transmission line’s impedance as the transmission line conducts either inductive or capacitive compensation. Because the primary goal of the TCSC is to regulate transmission line impedance by increasing its reactance in series with transmission lines, it cannot be installed at branches where transformers operate, resulting in improved loadability, transmission line transfer capacity, dynamic and static security, and enhanced transience. Figures 1 and Figure 2 show the TCSC device’s structure and location on the transmission line, respectively.

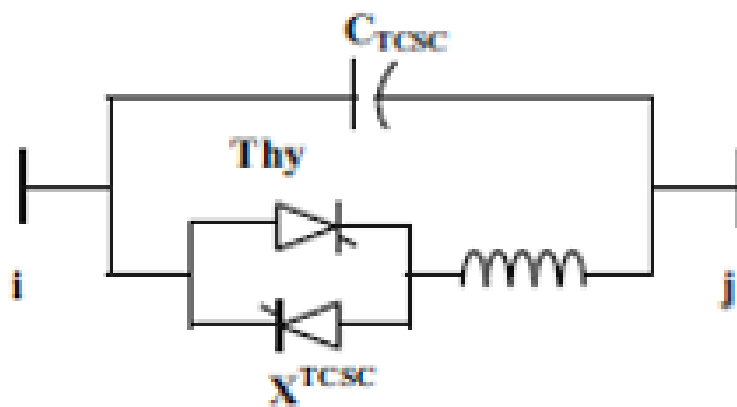

Figure 1: Basic structure of TCSC

As shown in Figure 2, the TCSC is a series compensator composed of a thyristor-controlled reactor and a capacitive bank connected in parallel. TCSC is a controllable reactance that is connected in series with a transmission line. Its purpose is to monitor power flow, reduce overload, and improve loadability by increasing or decreasing the transmission line reactance. The equivalent reactance of line produces the following equation based on the configuration:

$$x_{ij} = x_{ij}^{line} + x_{ij}^{TCSC} \quad (1)$$

Where,

x_{ij}^{line} is the transmission line reactance, and x_{ij}^{TCSC} is the TCSC reactance.

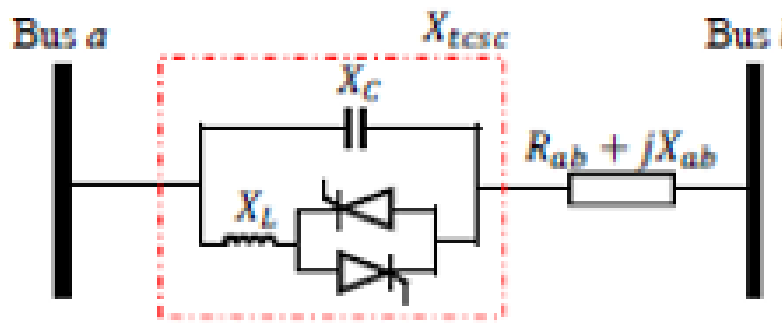

Figure 2: TCSC location on the transmission line [23]

It can also be written as follows:

$$x_{ij} = (1 + \gamma_{TCSC})x_{ij}^{line} \tag{2}$$

Where,

γ_{TCSC} is TCSC compensation ratio with value ranging between -0.8 to 0.2 as shown in (3).

$$-0.8 \leq \gamma_{TCSC} \leq 0.2 \tag{3}$$

The branch’s new admittance can be expressed as:

$$Y_{ij} = \frac{1}{(r_{ij}^{line} + j(x_{ij}^{line} + x_{ij}^{TCSC}))} \tag{4}$$

Where,

Y_{ij} is the bus admittance matrix with TCSC and r_{ij}^{line} is the transmission line resistance.

SVC is a FACTS device controller that connects to the transmission lines in parallel. SVC absorbs reactive power in the inductive mode and provides reactive power in the capacitive mode at its link point [4]. When connected to the bus, the SVC is an ideal reactive power provider; however, when shunt connected to a transmission line, it is a variable admittance. Figures 3 and Figure 4 depict the structure of SVC and its location on the bus, respectively.

The SVC is a VAR compensator with a shunt attached to it. The SVC, like the TCSC, incorporates a series capacitor bank shunted with a thyristor-controlled reactor, as shown in Figure 3. The system is then shunt connected to the bus via a step-up transformer bank, which raises the voltages to the required transmission levels (this transformer will be managed in the same way as the other transformers in the system). Because SVC can exchange dynamically reactive power (absorb or generate) with the network’s designated attached bus, it can control voltage magnitude [8, 3]. The SVC is represented by a variable shunt reactive susceptibility model in Figure 4. It injects or absorbs reactive power from the bus. The reactive power provided is limited the following equation.

$$-100MVAR \leq Q_{SVC} \leq 100MVAR \tag{5}$$

The reactive power values obtained by varying the SVC shunt susceptance value within the following range:

$$B_{SVC}^{min} \leq B_{SVC} \leq B_{SVC}^{max} \tag{6}$$

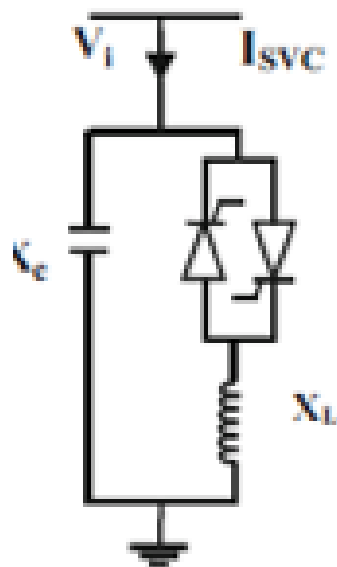

Figure 3: Basic Structure of SVC

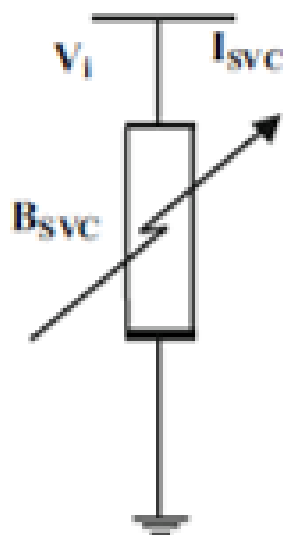

Figure 4: SVC location on the bus [23]

It is either inject or absorb reactive power from the bus.

Both SVC and TCSC have differences, and these differences complement each other to help minimize system power loss. The detailed differences between the two FACTS devices are shown in Table 1. The IEEE 26-bus RTS has been chosen as the project's test systems. 5 generators, 1 slack bus, 46 transmission lines, 7 transformers, and 8 shunt capacitors make up the bus system. Figure 5 illustrates the IEEE 26-Bus RTS single line diagram.

AIS is a computational technique, and the concept of AIS is derived from the biological vertebrate immune system [18], [19], which is based on natural immune system theories and aims to solve engineering and optimization problems [10]. AIS mimics the biological concepts of clone production, proliferation, and maturation. AIS algorithms are classified into four types: (a) negative

Table 1: Details on the differences of the multi-FACTS

No.	Details	TCSC	SVC
1.	Installation location	On the transmission line	At the bus
2.	Control variable	Compensation ratio	Reactive power (injected or absorbed)

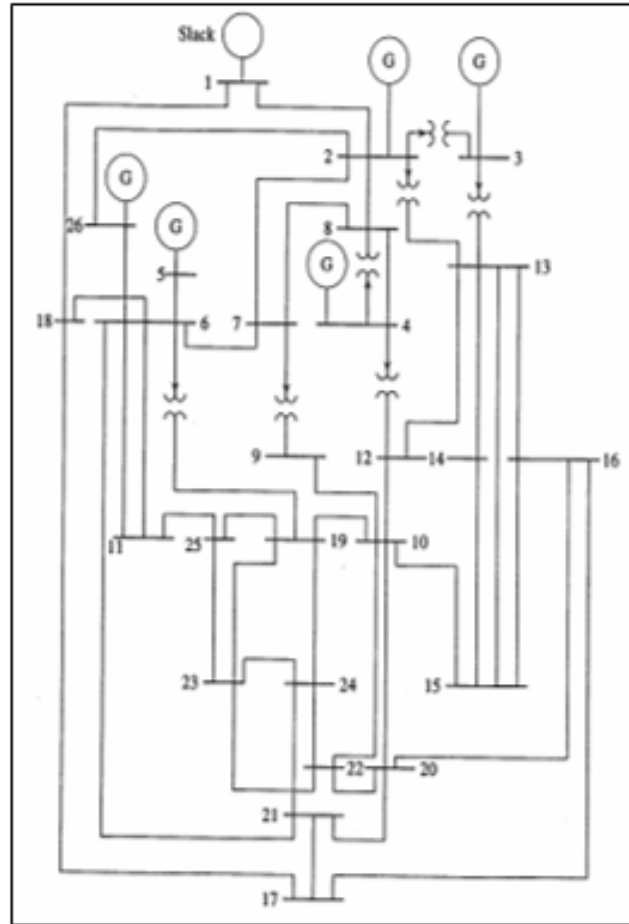

Figure 5: Single-line diagram of the IEEE 26-Bus RTS

selection algorithms [14], (b) clonal selection algorithms [6], (c) immune network algorithms [24], and (d) dendritic cell algorithms [11]. With the ongoing advancement of AIS algorithms, the negative representation of information, inspired by the self-nonsel discrimination method in Brain-Inspired Systems (BIS), is becoming a developing area of research in AIS [25].

According to Figure 6, the first process of AIS is initialization, which is a process of generating random numbers of the control variables, which in this project are the locations of TCSC and SVC as well as the sizes of SVC and TCSC’s reactance. During the initialization process, the fitness of system power loss is computed using (7) with the aid of the random numbers generated earlier. The objective function for this optimization problem is to minimize system power loss.

$$P_{loss} = \sum_{l=1}^{br} R_l I_l = \sum_{i=1}^b \sum_{j=1, i \neq j}^b [V_i^2 + V_j^2 - 2V_i V_j \cos(\delta_i - \delta_j)] Y_{ij} \cos \varphi_{ij} \tag{7}$$

Where,

br = the number of lines

- b = the number of buses
- R_l = the resistance of the line l^{th}
- I_l = the current that flow through the line l^{th}
- V_i = the voltage magnitude at node i^{th}
- δ_i = the angle at node i^{th}
- Y_{ij} = the magnitude of the line admittance between bus i^{th} and bus j^{th}
- φ_{ij} = the angle of the line admittance between bus i^{th} and bus j^{th}

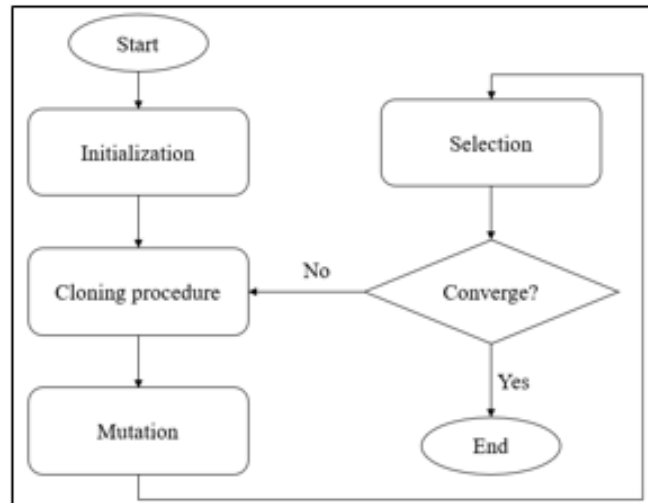

Figure 6: Flowchart of the AIS Algorithm [20]

Moving on to the cloning procedure. The number of previously generated control variables is multiplied during cloning. AIS is a population-based optimization, which means that as many solutions as possible are produced for the best to be chosen. The system power loss is calculated once more, this time with the aid of cloning individuals.

Following that, the cloned individuals are subjected to the mutation process to produce offspring. The system power loss is calculated once more using the mutated individuals. The offspring have the same population size as the cloned population of 200 individuals.

Following that, the outcome will be subjected to the selection process. During the selection process, the best 20 of 200 generated individuals who survived as the fittest will be chosen. But first, the 200 people are ranked from top to bottom, with the lowest system power loss at the top and the highest system power loss at the bottom. The first 20 control variables are then used in the next process.

Finally, the top 20 individuals will undergo the convergence test. The convergence test is used as an indicator to determine whether the global optima has already been found by introducing a stopping criterion that states that the difference between the first and twentieth fitness values of the selected population must be equal to or less than 0.0001. Otherwise, the procedures will be repeated until the global optima is found. The output of this AIS optimization process will be the best locations in the IEEE 26-Bus RTS to install TCSC and SVC units with the best reactance sizes and reactive power (injected or absorbed), respectively.

3. Results and discussion

As part of this project’s implementation, the MATLAB programming language software was used to simulate the process of installing FACTS devices SVC and TCSC on the IEEE 26-Bus RTS using

the AIS algorithm technique. Based on its size, it was decided that one unit of SVC and one unit of TCSC would be installed on the IEEE 26-Bus RTS. The developed AIS algorithm follows the AIS flowchart in Figure 6 and was written in MATLAB M-file to produce results that meet the expected outcomes. Table 2 displays the carefully selected control variables. The goal of the created program is to achieve the best results possible while adhering to the constraints of both FACTS devices.

Table 2: Details of the FACTS Devices selected for the installation

No.	Details	TCSC	SVC
1.	Installation location	On the transmission line	At the bus
2.	Control variable	Compensation ratio	Reactive power (VAR)
3.	Specification	$-0.8 \leq \gamma_{TCSC} \leq 0.2$	$-100MVAR \leq Q_{SVC} \leq 100MVAR$

Three case studies have been presented in solving this multi-type FACTS device installation problem for minimizing system power loss. The first case is the base case, in which the test system is in steady state. The second case is (N-1) line contingency, in which one transmission line is disabled. This line is rated as the weakest among the others. Finally, the third case is (N-2) line contingency, in which the two weakest transmission lines are shut down. It is critical to introduce line contingency cases to determine whether the proposed AIS technique can solve multi-type FACTS devices installation problem when the power system is not in steady state, as occurs in real-world problem. To achieve the best results, the program was run ten times in each case to ensure that it produced consistent optimization results.

3.1. Case 1: Base Case

It was ensured for this base case that the system power loss would not exceed 17.60 MW after the TCSC and SVC were optimally installed. Before the FACTS devices are installed, the system power loss is 15.53 MW. Table 3 summarizes the Case 1 results. The table displays the AIS optimization results for 20 runs. The locations of TCSC and SVC units in the IEEE 26-Bus RTS, as well as their sizing and system power loss, can be seen.

Table 3: Summarized results for Case 1

No. of run	Location of SVC (Bus no.)	Sizing of SVC (MVAR)	Location of TCSC (Line no.)	Compensation ratio, γ_{TCSC}	Sizing of XTCSC (p.u)	Power Loss (MW)
1	9	-36.74	4-8	0.1910	0.0079	14.88
2	9	-36.74	4-8	0.1910	0.0079	14.88
3	9	-36.74	4-8	0.1910	0.0079	14.88
4	9	-36.74	4-8	0.1910	0.0079	14.88
5	9	-36.74	4-8	0.1910	0.0079	14.88
6	9	-36.74	4-8	0.1910	0.0079	14.88
7	9	-36.74	4-8	0.1910	0.0079	14.88
8	9	-36.74	4-8	0.1910	0.0079	14.88
9	9	-36.74	4-8	0.1910	0.0079	14.88
10	9	-36.74	4-8	0.1910	0.0079	14.88

According to Table 3, the best location for SVC unit is at bus 9, with a sizing of 36.74 MVAR injected to the bus. Meanwhile, TCSC unit is located on line 4-8, with a compensation ratio of

0.1910. As a result, the TCSC reactance is 0.0079 p.u. The following is an example of TCSC reactance calculation:

$$ine(4 - 8) : X_{ab} = 0.0207p.u \tag{8}$$

$$X'_{ab} = X_{ab} + X_{TCSC} \tag{9}$$

$$X_{TCSC} = X'_{ab} - X_{ab} = 0.0286 - 0.0207 = 0.0079p.u \tag{10}$$

Following the installation of the TCSC and SVC units, the system power loss was reduced to 14.88 MW. This demonstrates that AIS has successfully identified the best locations and sizings for the installation of TCSC and SVC units for this steady state condition of the IEEE 26-Bus RTS.

3.2. Case 2: (N-1) line contingency

Lines 6-11 was taken offline for this Case 2. Table 4 displays the optimization results for Case 2 after ten runs. According to Table 4 of Case 2, the best location for SVC discovered via AIS is at bus 9, with a sizing of 36.74 MVAR injected to the bus. Meanwhile, with a compensation ratio of 0.1910, the optimal location of TCSC is at line 4-8, and the results are the same as in Case 1. However, the system power loss for this case after the installation of the TCSC and SVC units is 14.85 MW, which is less than 15.51 MW before the installation for this (N-1) line contingency condition.

Table 4: Summarized results for Case 2

No. of run	Location of SVC (Bus no.)	Sizing of SVC (MVAR)	Location of TCSC (Line no.)	Compensation ratio, γ_{TCSC}	Sizing of XTCSC (p.u)	Power Loss (MW)
1	9	-36.74	4-8	0.1910	0.0079	14.85
2	9	-36.74	4-8	0.1910	0.0079	14.85
3	9	-36.74	4-8	0.1910	0.0079	14.85
4	9	-36.74	4-8	0.1910	0.0079	14.85
5	9	-36.74	4-8	0.1910	0.0079	14.85
6	9	-36.74	4-8	0.1910	0.0079	14.85
7	9	-36.74	4-8	0.1910	0.0079	14.85
8	9	-36.74	4-8	0.1910	0.0079	14.85
9	9	-36.74	4-8	0.1910	0.0079	14.85
10	9	-36.74	4-8	0.1910	0.0079	14.85

3.3. Case 3: (N-2) line contingency

For Case 3, lines 6-11 and 10-12 have been removed from the IEEE 26-Bus RTS. Table 5 summarizes the optimization results for Case 3, which includes ten runs. According to the table, the best location to install an SVC unit is on bus 9 with a size of 36.74 MVAR injected into the bus. At the same time, line 4-12 with a compensation ratio of 0.1910 is the best place to install a TCSC unit. Furthermore, the FACTS devices were installed properly, resulting in a reduction of system power loss from 16.59 MW (pre-installation) to 15.69 MW (after installation).

3.4. Comparison between cases

Table 6 compares the outcomes of the three scenarios. Because the line contingency cases are implemented to represent the practical scenario when a fault occurs, the proposed AIS program can still find the optimal locations and sizing of the TCSC and SVC units in the power system. According

Table 5: Summarized results for Case 3

No. of run	Location of SVC (Bus no.)	Sizing of SVC (MVAR)	Location of TCSC (Line no.)	Compensation ratio, γ_{TCSC}	Sizing of XTCS (p.u)	Power Loss (MW)
1	9	-36.74	4-8	0.1910	0.0079	15.69
2	9	-36.74	4-8	0.1910	0.0079	15.69
3	9	-36.74	4-8	0.1910	0.0079	15.69
4	9	-36.74	4-8	0.1910	0.0079	15.69
5	9	-36.74	4-8	0.1910	0.0079	15.69
6	9	-36.74	4-8	0.1910	0.0079	15.69
7	9	-36.74	4-8	0.1910	0.0079	15.69
8	9	-36.74	4-8	0.1910	0.0079	15.69
9	9	-36.74	4-8	0.1910	0.0079	15.69
10	9	-36.74	4-8	0.1910	0.0079	15.69

to the comparison, the greater the transmission line outage, the greater the system power loss, but it remains within the constraint value. These line contingencies conditions help to deal with real-world scenarios in which lines go down due to electrical faults. However, regardless of the inconvenience, the installation location of FACTS devices can still be generated and will be located at the most suitable location. Regardless, the system power loss is minimized. These findings show that the installation location of both devices, SVC and TCSC, has a consistent result.

Table 6: Comparison between the three cases

Case	Case 1: Base case	Case 2: (N-1) line contingency	Case 3: (N-2) line contingency
Outage Line(s)	-	1	2
No. of transmission line	46	45	44
Location of SVC	9	9	9
Sizing of SVC (MVAR)	-36.74	-36.74	-36.74
Location of TCSC	Line 4-8	Line 4-8	Line 4-8
XTCS (p.u)	0.0079	0.0079	0.0079
Power loss (MW)	14.88	14.86	15.69

4. Conclusion

In conclusion, this paper successfully presented the AIS optimization technique for the installation of multi-type FACTS devices, TCSC and SVC, in the power system. Three case studies were presented in finding the optimal locations and sizings of the FACTS devices to minimize system power loss. According to the optimization results, AIS is a prospective computational intelligence technique that can be used to optimally install multi-FACTS devices in the best location with their optimal sizing while taking system constraints into account. This is evident when the system power loss produced by AIS is compared to the system power loss prior to installation. Across multiple runs, the proposed AIS algorithm produced consistent results. Furthermore, in this project, the line contingency approach was used to vary the input and execute an acceptable output to validate the

system works even during disruptions. This implementation improves system stability while simultaneously reducing system power loss, which has always been a problem in the electrical power system. Moreover, the power system operating costs will be reduced because of the reduced system power loss.

In the future, the research project can be done with different FACTS devices to see if the system is more likely to optimize or not. Different types of FACTS devices provide different benefits; thus, it is more important to investigate in the optimization of a power system to achieve the best result possible. Since this project has used two FACTS devices, SVC and TCSC, it can be expanded by implementing Unified Power Flow Controller (UPFC) and Static Synchronous Compensator (STATCOM), which have been associated with instantaneous minimization of voltage deviation at load buses and real power loss in transmission lines in various research papers. Furthermore, this project can be improved by analyzing transmission line contingency to select the most suitable transmission lines in line contingency cases. As a result, the proposed AIS optimization technique is more refined in terms of accuracy.

Acknowledgement

The authors would like to thank the Ministry of Higher Education Malaysia (MOHE) for funding this research. The MOHE has fully funded this research through the Fundamental Research Grant Scheme (FRGS), with the project code: FRGS/1/2020/TK0/UNITEN/03/4.

References

- [1] U. Aickelin and D. Dasgupta, *Artificial Immune Systems Tutorial*, A Bibliogr. Comput. Sci. Dep. Univ. MEMPHIS USA, 60 (4) (2010) 1–29.
- [2] Y. Amrane and M. Boudour, *Optimal reactive power dispatch based on particle swarm optimization approach applied to the Algerian electric power system*, in 2014 IEEE 11th International Multi-Conference on Systems, Signals and Devices, SSD 2014, 2014.
- [3] K. Balamurugan, R. Muralisachithanandam, and V. Dharmalingam, *Performance comparison of evolutionary programming and differential evolution approaches for social welfare maximization by placement of multi type FACTS devices in pool electricity market*, Int. J. Electr. Power Energy Syst., 67 (2015) 517–528.
- [4] F. Berrouk and K. Bounaya, *Optimal Power Flow For Multi-FACTS Power System Using Hybrid PSO-PS Algorithms*, J. Control. Autom. Electr. Syst., 29 (2)(2018) 177–191.
- [5] R. K. Bindal, *A Review of Benefits of FACTS Devices in Power System*, Ijeat, 3 (4) (2014) 105–108.
- [6] L. Castro, L. Castro, F. J. V Zuben, and F. J. V Zuben, *Learning and optimization using the clonal selection principle*, IEEE Trans. Evol. Comput., 6 (3)(2002) 239–251.
- [7] G. Deb, K. Chakraborty, and S. Deb, *Voltage stability analysis using reactive power loading as indicator and its improvement by FACTS device*, in 1st IEEE International Conference on Power Electronics, Intelligent Control and Energy Systems, ICPEICES 2016, (2017) 1–5.
- [8] S. Dixit, L. Srivastava, A. Singh, and G. Agnihotri, *Optimal Placement of TCSC For Enhancement of Power System Stability Using Heuristic Methods: An Overview*, Int. J. Hybrid Inf. Technol., 8 (6) (2015) 367–374.
- [9] M. El-Azab, W. A. Omran, S. F. Mekhamer, and H. E. A. Talaat, *Allocation of FACTS devices using a probabilistic multi-objective approach incorporating various sources of uncertainty and dynamic line rating*, IEEE Access, 8 (2020) 167647–167664.
- [10] J. D. Farmer, N. H. Packard, and A. S. Perelson, *The immune system, adaptation, and machine learning*, Phys. D Nonlinear Phenom., 22(1–3)(1986) 187–204.
- [11] J. Greensmith, U. Aickelin, and J. Twycross, *Articulation and clarification of the dendritic cell algorithm*, in Lecture Notes in Computer Science (including subseries Lecture Notes in Artificial Intelligence and Lecture Notes in Bioinformatics), 4163 (2006) 404–417.
- [12] V. K. Gupta, S. Kumar, and B. Bhattacharyya, *Enhancement of Power System Loadability with FACTS Devices*, J. Inst. Eng. Ser. B, 95 (2) (2014) 113–120.
- [13] T. Jansen and C. Zarges, *Artificial immune systems for optimisation*, in GECCO'12 - Proceedings of the 14th International Conference on Genetic and Evolutionary Computation Companion, (2012) 1059–1077.

- [14] D. C. Johnny et al., *ADADELTA: An Adaptive Learning Rate Method*, IEEE Access, 7 (November) (2018) 51886–51898.
- [15] N. M. Jothi Swaroopan and P. Somasundaram, *Fuzzified PSO algorithm for OPF with FACTS devices in interconnected power systems*, in Lecture Notes in Computer Science (including subseries Lecture Notes in Artificial Intelligence and Lecture Notes in Bioinformatics), 6466 (2010) 468–480.
- [16] S. A. Jumaat, I. Musirin, M. M. Othman, and H. Mokhlis, *Optimal location and sizing of SVC using particle swarm optimization technique*, in Proceedings - 1st International Conference on Informatics and Computational Intelligence, ICI 2011, (2011) 312–317.
- [17] S. A. Jumaat, I. Musirin, M. M. Othman, and H. Mokhlis, *Computational intelligence based technique in multiple facts devices installation for power system security*, J. Theor. Appl. Inf. Technol., 46 (2)(2012) 537–549.
- [18] A. Kazemi and B. Badrzadeh, *Modeling and simulation of SVC and TCSC to study their limits on maximum loadability point*, Int. J. Electr. Power Energy Syst., 26 (8) (2004) 619–626.
- [19] A. K. Mohanty and A. K. Barik, *Power System Stability Improvement Using FACTS Devices*, Int. J. Mod. Eng. Res., 1 (2) (2009) 666–672.
- [20] S. C. Mohd Nasir et al., *Multistage artificial immune system for static VAR compensator planning*, Indones. J. Electr. Eng. Comput. Sci., 14(2019) 346–352.
- [21] D. Murali, M. Rajaram, and N. Reka, *Comparison of FACTS Devices for Power System Stability Enhancement*, Int. J. Comput. Appl., 8 (4)(2010) 30–35.
- [22] S. Nagalakshmi and N. Kamaraj, *Comparison of computational intelligence algorithms for loadability enhancement of restructured power system with FACTS devices*, Swarm Evol. Comput., 5 (2012) 17–27, 2012.
- [23] A. A. Sallam and O. P. Malik, *Power flow analysis*, in Power System Stability: Modelling, Analysis and Control, (2015) 107–130.
- [24] J. Timmis and M. Neal, *A resource limited artificial immune system for data analysis*, Knowledge-Based Syst., 14 (3) (2001) 121–130.
- [25] Y. Wang and T. Li, *Local feature selection based on artificial immune system for classification*, Appl. Soft Comput. J., 87 (2020) 105989.
- [26] X. Zhang et al., *Optimal allocation of series FACTS devices under high penetration of wind power within a market environment*, IEEE Trans. Power Syst., 33 (6)(2018) 6206–6217.