



Simulation of optical fiber cable regarding bandwidth limitations

Aqeel Hamza Al-fatlawi^a, Musaddak M. Abdul Zahra^{b,c,*}, Hussein Ali Rassool^d

^aDepartment of computer Techniques, Imam Kadhum College, Iraq.

^bComputer Techniques Engineering Department, Al-Mustaqbal University College, Babylon 51001, Iraq.

^cElectrical Engineering Department, College of Engineering, University of Babylon, Babylon 51001, Iraq.

^dDepartment of Nursing , Altoosi University College, Najaf, Iraq.

(Communicated by Madjid Eshaghi Gordji)

Abstract

The optical fiber stands for an exceptionally appealing correspondence medium since it offers an enormous data transmission and low lessening, also, can in this manner encourage requesting administrations like excellent visual communication as well alternatives in PC organizations. In this study, a good strategy simulation based on mathematical equations has been presented for a unique optical channel correspondence. Also, this paper shows the nonlinear analysis phenomenon of fiber scattering, modulator as well recipient reaction periods, coding type of waveform. The light source spectral width have influence to the presentation of the fiber optics correspondence like link length, information rate, BER. Additionally, this paper show the force and rising period, spending plan is utilized to get a good guess of the communication length as well the piece rate utilizing optical framework test scheme.

Keywords: Nonlinear Analysis, Optical Networks, Fiber Optical telecommunication, Power Budget, Rise Time Budget, Fiber Dispersion.

1. Introduction

A piece of a correspondence direct in optical fiber exchanges or optical fiber frameworks is moving an optical wave separated of transmitter to be objective with little incident in quality as could truly be anticipated. Before long, “optical fiber” extend light pulses imparted by means of particular or

*Corresponding author

Email addresses: aqeelhamah@alkadhum-col.edu.iq (Aqeel Hamza Al-fatlawi),
musaddaqmahir@mustaqbal-college.edu.iq (Musaddak M. Abdul Zahra)

Received: June 2021 Accepted: October 2021

chromatic dissipating. Supremely, a correspondence medium must not ruin a nature of an optical sign dispatched into it. At the point when beats of optical link have been spread sincerely a piece of their apportioned piece space, the imparted signal is defiled effectively to the point that it gets hard to recuperated the at first sign along huge accuracy. The dispersing issue is by and large genuine for multimode fibers [5]. It is in this way, the majority of fiber optic structures use single-mode fibers. Chromatic dispersing really prompts beat extending in any case, its influence can be diminished by adjusting a critical width of an optical source or by using a dissipating the heads strategy. Today in abundance of 80% of the realm's significant distance traffic is expanded "optical fiber" joins. Media correspondences usages of fiber-optic connection are broad, going from overall associations to work stations [10] These incorporate the transmitting data, voice and video over distances of not by and large a meter to numerous kilometers, using one of a couple standard fiber plans in one of a couple of connection plans. Fiber optics have been the business specification for the natural transmitting telecom data. Fiber optics can remain a critical significant part in a movement of broadband organizations. The mark of this study is to propagate and upgrade a modernized fiber optic association [4] This association will be employed as a singular redirect in electronic optical correspondence system, and provide nuances for brand name transmitter, gatherer, and fiber to design besides, amass this single redirect in optical correspondence, in like manner this study show the mechanism of rising time in transmitter and authority, sort of coding (NRZ and RZ), dissipating of the fiber optic channel are influenced to a structure and performance's, for instance, data rate conveyed, fiber length, and spot bumble rate (BER).

2. Optical Transmission Structure

A transmitter, an optical origin, a communication channel, an identifier, and a recipient comprise the fundamental optical correspondence system. The fiber optic association system resembles a correspondence structure in almost every way. The data source transmits a high-level or electrical signal to a transmitter, which includes an electrical stage that drives an optical source to maintain the light wave carrier's equilibrium. A semiconductor laser or a light emitting diode (LED) serves as the optical source for the electrical-optical conversion [16] The transmission medium is of the "optical fiber" type, and the recipient is comprised of an optical pointer that drives an additional electrical stage, resulting in the demodulation of an optical carrier. Numerous components contribute to the structure plan, including the light source (transmitter influence), coupling difficulties, the response period of the light source and transmitter, signal coding, unite and connector failure, fiber type (single – or – multimode), fiber narrowing and dissipation, fiber focus distance across, working recurrence, optical enhancers, and direct versus abnormal change of trajectories. Numerous these variables are inextricably linked. For the model, fiber choking and dissipation are dependent on the frequency of work, just as they are on the fiber type. Coupling incidents are determined by factors such as fiber NA and focus estimation. Additionally, there are components to keep in mind for the optical association plan between the transmitter source, fiber optic association, and recipient (photo pointer). These components are necessary for dismantling an organization:

1. The sending part length or "fiber optic" contact distance.
2. The medium bandwidth or capacity (bit data rate).
3. The "bit-error rate" ("BER").
4. "Power Budget".
5. "Rise time budget".

3. Methodology

The performance of the fiber optic communication system affects with fiber misfortunes and losses, which address restricting variable since they diminish the sign influence arriving at the collector . As optical beneficiaries need a specific least measure of force for recuperating the sign precisely, the transmission distance is intrinsically restricted by fiber misfortunes. In any case, low-misfortune strands are as yet needed since dividing among intensifiers is set by fiber misfortunes [10] Actually, the most performance affective losses as well parameters concerning the fiber optical cables can be summarized below:

A) Attenuation

Attenuation address the one most significant qualities of an optical fiber that decide the data conveying limit of a fiber optic correspondence framework. The fiber misfortune is alluded to assign lessening or just attenuation, which is a significant property of an “optical fiber” on the grounds that, along with signal bending components, it decides the greatest transmission distance conceivable between a transmitter and a collector (or a speaker) previously the sign force should be supported to a suitable level over the sign clamor for high-loyalty gathering. The level of the weakening relies upon the frequency of the light and on the fiber material. Loss in a framework can be communicated as the accompanying [5]

$$Loss (dB) = -10 \text{ Log} \frac{P_{out}}{P_{in}} \quad (3.1)$$

Where P_{in} is the input power to the fiber also P_{out} is the power provided at the output of the fiber. Frequently, loss in “optical fiber” is further represented by terms of decibels per kilometer (dB/km) [10]

$$\alpha (dB/km) = -\frac{10}{L} \text{ Log} \frac{P_{out}}{P_{in}} \quad (3.2)$$

Where α , is the attenuation coefficient.

The optical fiber can be single mode (SM) or multimode (MM). For short distance communications, a multimode fiber is used; these strands have a high limit and unwavering quality. The primary difference between a single mode fiber and a multimode fiber is that the multimode fiber has a larger center breadth and a larger mathematical opening estimation. As a result, the fiber’s light assembly limit is quite high. The data transmission distance of a multimode fiber is significantly less than that of a single mode fiber, as the former supports multiple generating modes. Similarly, single mode (SM) fiber has a lower attenuation coefficient (α) than multimode fiber (MM) [19].

Bending losses

Dispersing and absorption loss because of the inherent qualities of the “optical fiber”. When the “optical fiber” is made, we can confront these misfortunes. Notwithstanding these misfortunes when any “optical fiber” is set up inside the framework, a few misfortunes happen because of climate and ill-advised treatment of the “optical fiber” [20] Twist misfortune is a marvel which happens at the point when the “optical fiber” is bowed over the basic curve sweep. The curve sweep changes for various “optical fiber”. Reasons for these twist misfortune are helpless link plan, minuscule fiber deformity and tight curves. The twist misfortune can be of two types. They are: full scale bowing misfortune and miniature twisting misfortune, as represented in Figure 1. Full scale twist misfortune happens when the basic point is surpassed at high request mode and the light is refracted out of the center into the cladding locale. The large scale twist misfortune can be seen with the unaided eye

and these twists can be redressed up partially. Miniature twist misfortune is only inverse to the full scale twist. Miniature twist misfortune happens when the pressing factor is applied on the outside of the fiber and because of the twisting of center cladding interface. The miniature twist misfortune is too little to even consider being seen with the unaided eye [11].

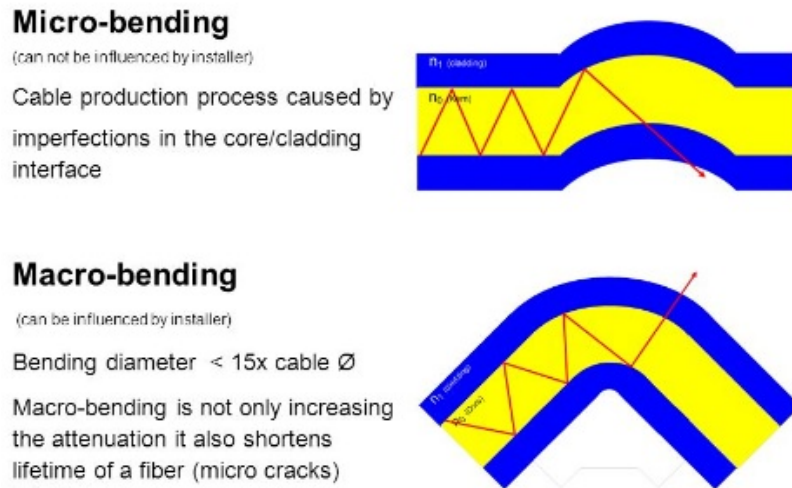
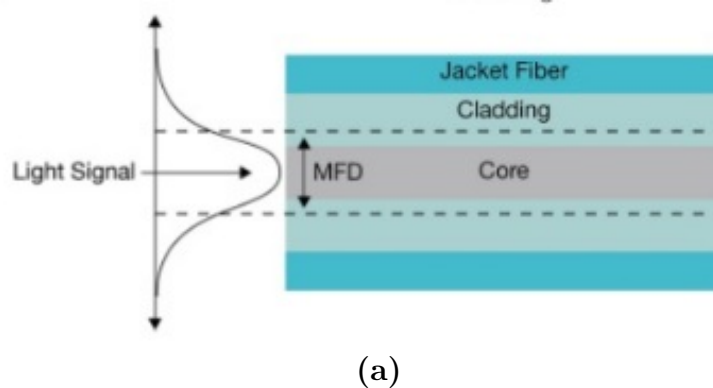

Figure 1: Losses via a) macro-bending, b) micro-bending

The absolute most significant factor that decides the powerlessness of a fiber to bowing that incites misfortune is the Mode Field Diameter (MFD). MFD addresses the territory where the light goes through and incorporates the center and a piece of the cladding. A more modest mode field measurement demonstrates that light is all the more firmly limited to the fiber center and, in this way is less inclined to spillage when the fiber is circled. Figure 2 shows the relationship of light force, MFD where width of center and the frequencies are the significant boundaries in deciding the affectability of twist misfortune [18]



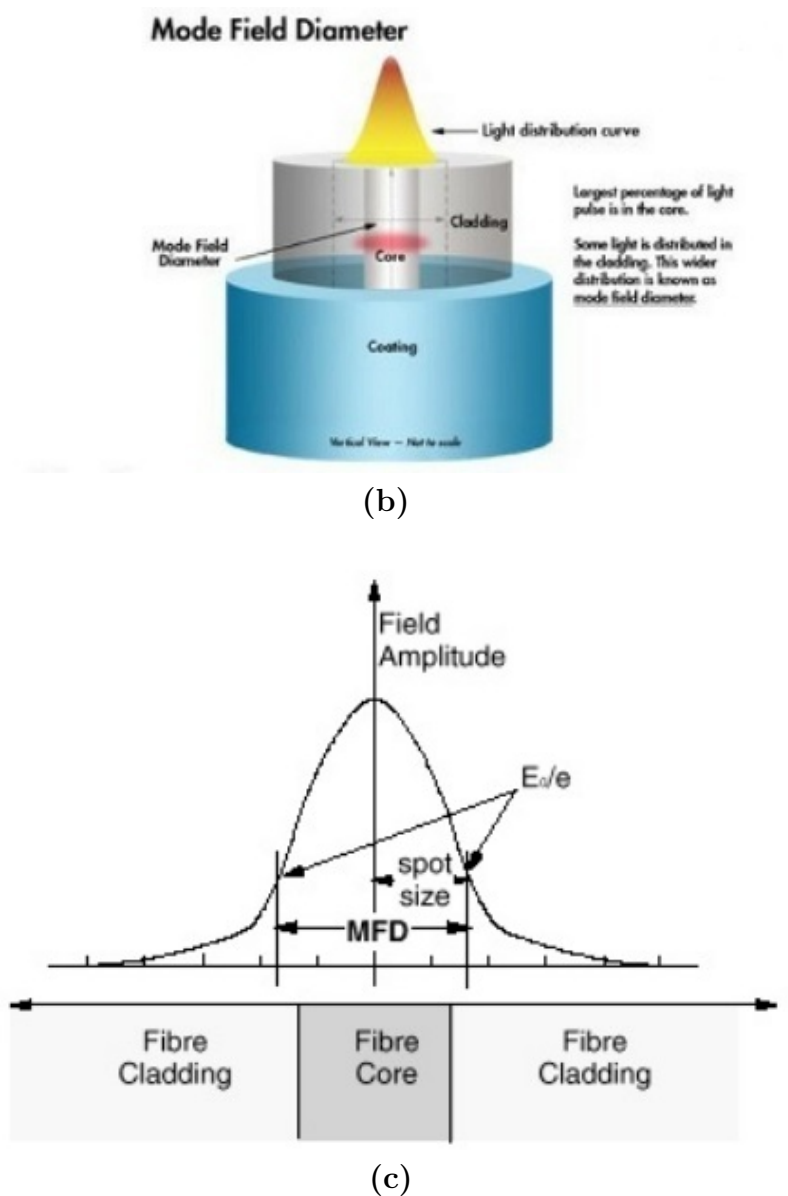

Figure 2: The relationship between light and MFD, a) view1, b) view 2, c) view 3

C) Splices Losses

A fiber splice is a lasting or transitory low-misfortune connection between two strands. Such a bond can be made by utilizing by the same token combination grafting or mechanical joining. Most grafts are lasting and commonly are utilized to make long optical connections or in circumstances where successive association and disengagement isn't required. The actual contrasts in strands that lead to graft misfortunes are equivalent to those talked about above for connectors and result in what is called inborn misfortune. These fiber-related contrasts remember varieties for center breadth, center territory ellipticity, mathematical gap, and center cladding concentricity of every fiber. Extraneous losses depend on how well the strands are readied and the consideration taken to make the join. As a rule, grafts offer a lower return misfortune, lower constriction, and more noteworthy actual strength than connectors. Additionally, grafts are normally more affordable per join (or per joint) than connectors, require less work, establish a more modest joint for incorporation into graft terminations,

offer a superior airtight seal, and permit either individual or mass grafting.

D) Quality Factor & Bit Error Rate

In any an optical transmission framework, the principle intention is to move information starting with one spot then onto the next with the least likelihood of mistake. One of the primary boundaries portraying the nature of the information connect is a piece mistake rate BER (Bit Blunder Rate), with BER is feasible to think about the nature of various frameworks for information transmission. Nevertheless, Q-factor describes the nature of an advanced sign from a simple point. The Q-factor and the bit error rate (BER) are the two primary factors limiting the transmission distance in optical correspondence frameworks. To transmit signals over long distances, it is critical that the fiber has a low BER and a high Q-factor. The Q-factor can be utilized to give a rough an incentive for the BER, the connection between Q-factor and the mistake rate can be communicated as follows [6, 17].

$$BER = \frac{1}{2} \operatorname{erfc}\left(\frac{Q}{\sqrt{2}}\right) \approx \frac{1}{Q\sqrt{2\pi}} \exp\left(-\frac{Q}{2}\right) \quad (3.3)$$

Where erfc is the correlative blunder work. The Q-factor can be communicated as far as the electrical sign to-commotion proportion (SNR) by the recipe:

$$Q = \frac{SNR\sqrt{2TB_{opt}}}{1 + \sqrt{1 + 2SNR}} \quad (3.4)$$

Where T stands for the bit period and B_{opt} denotes a bandwidth of a rectangular optical filter, and SNR is a metric used in science and engineering to quantify the amount of noise that has corrupted a signal. It is defined as the ratio of the power of the signal to the power of the noise that corrupts the signal, as shown in the following equation:

$$SNR = \frac{I_1 - I_0}{I_0} \quad (3.5)$$

Here I_0 and I_1 represent the means of the low-pass filtered electrical current under a sampling time for the spaces and marks [12].

E) Power & Rise Time Budgets

The fiber optic correspondence plan has two enormous limits: the force financial plan and the ascent time financial plan. The common optical power transmitted into the correspondence channel must be as broad as feasible in order to redesign the bit error rate (BER) at the authority end. If the signal is very weak as it appears at the structure's farthest end, the data will be challenging to detach from the establishment disturbance, which will increase the number of data piece mix-ups. The obtained force should be sufficiently large to hold the BER to a low value; however, the obtained force should be small sufficiently for avoiding causing damage to the authority. The base power requirement can be determined by determining the power spending structure that is most conducive to measuring the fiber length, decreasing, and overcoming difficulties in connectors and joins. The force spending plan is as follows [1]:

$$powerbudget (dB) = Ptx [dB] + Pmin [dB] \quad (3.6)$$

In reference to condition (3.6), the force financial plan is based on the communicated power to the base force that is expected to execute the fundamental movement at the piece rate sent and the BER. The choking and complete incident permitted in the transmission association will be known from the power spending plan, and this total narrowing tends to the fiber optic tightening imparted in (dB/km), despite the coupling setback caused by the center's relationship to the association.

$$\alpha_{fiber}L + \alpha_{coupling}N \leq powerbudget [dB] \quad (3.7)$$

In reference to condition (3.6), the force financial plan is based on the communicated power as well as the base force's expectation to execute the fundamental movement at the piece rate sent and the BER. The choking and complete incident permitted in the transmission association will be known from the power spending plan, and this total narrowing tends to the fiber optic tightening imparted in (dB/km), despite the coupling setback caused by the center's relationship to the association. As shown in condition (3.6).

$$\Delta t_{overall} = \sqrt{\Delta t_{transmitter}^2 + \Delta t_{receiver}^2 + \Delta t_{fiber}^2} \quad (3.8)$$

The total square of the transmitter rise time, beneficiary ascent time, and a beat spreading instigated by fiber scattering is the general reaction time. While the transmitter and beneficiary ascent and full times are specified on information sheets, fiber reaction times should be computed using the fiber length, trademark scattering for each unit length, and source unearthly width. Scattering can be classified into three types: modular, chromatic (material and waveguide scattering), and polarization-mode scattering. While modular scattering is negligible in single mode filaments, chromatic and polarization-mode scattering are critical.

The bandwidth of an optical fiber interchange framework refers to the maximum speed of data transfer or, more precisely, the rate at which computerized information can be transmitted. The all-out limit of a fiber with frequency division multiplexing is equal to the sum of the limits of all optical channels carried by the fiber. The single channel limit is determined by how quickly each component of the framework reacts to changes in signal force. In practice, transmission speed is primarily determined by the transmitter, fiber, and collector properties. Cost and security considerations dictate that the transmitter capacity be kept to a minimum acceptable level; additionally, select a transmitter light source with sufficient capability to enable the framework to operate in the worst-case scenario with the most extreme misfortunes considered above. Additionally, the plan should include a buffer above the beneficiary's basic requirements to account for framework maturation, variations, and fixes, such as grafting a broken link. In any case, it should not transmit an excessive amount of force to the collector [19]

The total response time is defined as the square root of the sum of the squares of the transmitter rise time, the recipient rise time, and the beat spreading caused by fiber dispersing. While the rising and full times of the transmitter and recipient are documented on data sheets, fiber response times should be determined using the fiber length, the brand name dissipating per unit length, and the source ridiculous width. There are three types of dispersing: isolated, chromatic (measures how much material and waveguide dissipates), and polarization-mode dispersing. Although secluded dispersing is zero in single mode fibers, chromatic and polarization-mode dispersing are essential.

The basic exchange rate, or, on the other hand, the rate at which automated data may be conveyed, is unquestionably the transmission capacity of an optical fiber trading structure. In recurrent division multiplexing, the full scale cutoff of a fiber refers to the restriction of all optical channels that the fiber travels through. The speed with which all of the system's bits respond to changes in signal power determines the single channel limit. In practice, the transmitter, fiber, and authority properties all have a role in transmission speed. It is sufficient to keep the transmitter capability to a minimum commendable level from a cost and security standpoint; additionally, select a transmitter light source with sufficient capacity to engage the system to operate in the most heinous case conditions with the fewest possible hardships previously considered. Furthermore, the arrangement should allow for structure development, changes, and corrections, such as reconnecting a broken link, in addition to the recipient's basic requirements. Regardless, it should not send the gatherer an excessive quantity of power [19].

F) Dispersion

Dispersion is a critical factor in determining the performance quality of “optical fiber,” is defined as the broadening of a pulse in fiber, and increases with the length of “optical fiber,” the impact of this factor on fiber performance is well-known (ISI) Inter-symbol interference takes place when dispersion causes pulses to overlap and become undetectable; in other words, dispersion is the primary factor limiting the bandwidth of an optical signal transmitted through a “optical fiber.” Modal dispersion, chromatic dispersion, and polarization mode dispersion are the three types of dispersion.

1. Modal dispersion is categorized as pulse broadening caused by a time delay between two order modes and higher order modes. This type of dispersion occurs in multimode fiber due to the bandwidth limitation associated with the various wave velocities.
2. Chromatic dispersion (CD): The broadening pulse occurs as a result of the different velocities passing through the fiber; the reason for these differences is the refractive index of the glass fiber, which may vary due to material variation; this type occurs in single mode fiber.
3. Polarization mode dispersion (PMD): This type of dispersion occurs as a result of birefringence along the length of the fiber, which causes various polarization modes to pass at various speeds, resulting in rotation polarization sides.

Indeed, both material and waveguide dispersion are instances of chromatic dispersion, as they are both frequency dependent. Waveguide dispersion is influenced by the frequency dependence of a specific mode's propagation constant due to the wave guiding effect. Intra mode dispersion is the combined effect of material and waveguide dispersion on a single mode.

Modal dispersion is caused by differences in the propagation constants of various modes; it is also referred to as inter-mode dispersion. Modal dispersion occurs only when a multimode fiber is excited in more than one mode. It persists in the absence of chromatic dispersion. When only one mode is excited in a fiber, even if the fiber is multimode, only intra-mode chromatic dispersion must be considered.

The materials of interest for optical fiber are pure silica and doped silica. The refractive index n , the group index n_g , and the group velocity dispersion D are the relevant parameters. In the wavelength range 200 nm to 4 m, the index of refraction of pure silica is given by the following empirically fitted “Sellmeier” equation:

$$n^2 = 1 + \frac{0.6961663\lambda^2}{\lambda^2 - (0.0684043)^2} + \frac{0.4079426\lambda^2}{\lambda^2 - (0.1162414)^2} + \frac{0.8974794\lambda^2}{\lambda^2 - (9.896161)^2} \quad (3.9)$$

where λ is in micrometers. The index of refraction of silica can be altered by adding dopants, allowing for greater control over the index profile of a fiber.

As a result, and as previously stated, fiber dispersion results in optical pulse broadening and consequent degradation of digital signals. Additionally, as the ISI becomes more noticeable, an increasing errors may be encountered on the digital optical channel. Figure 3 depicts fiber dispersion and the pulse ISI.

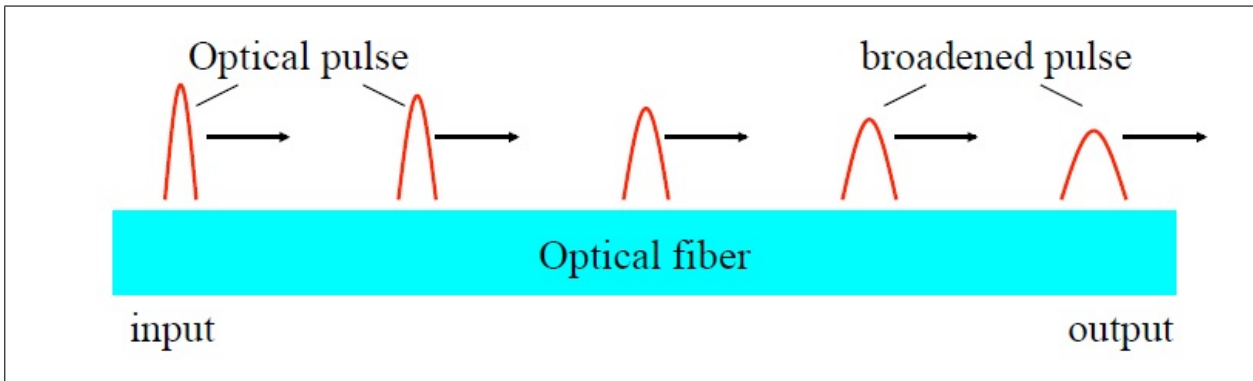

(a)

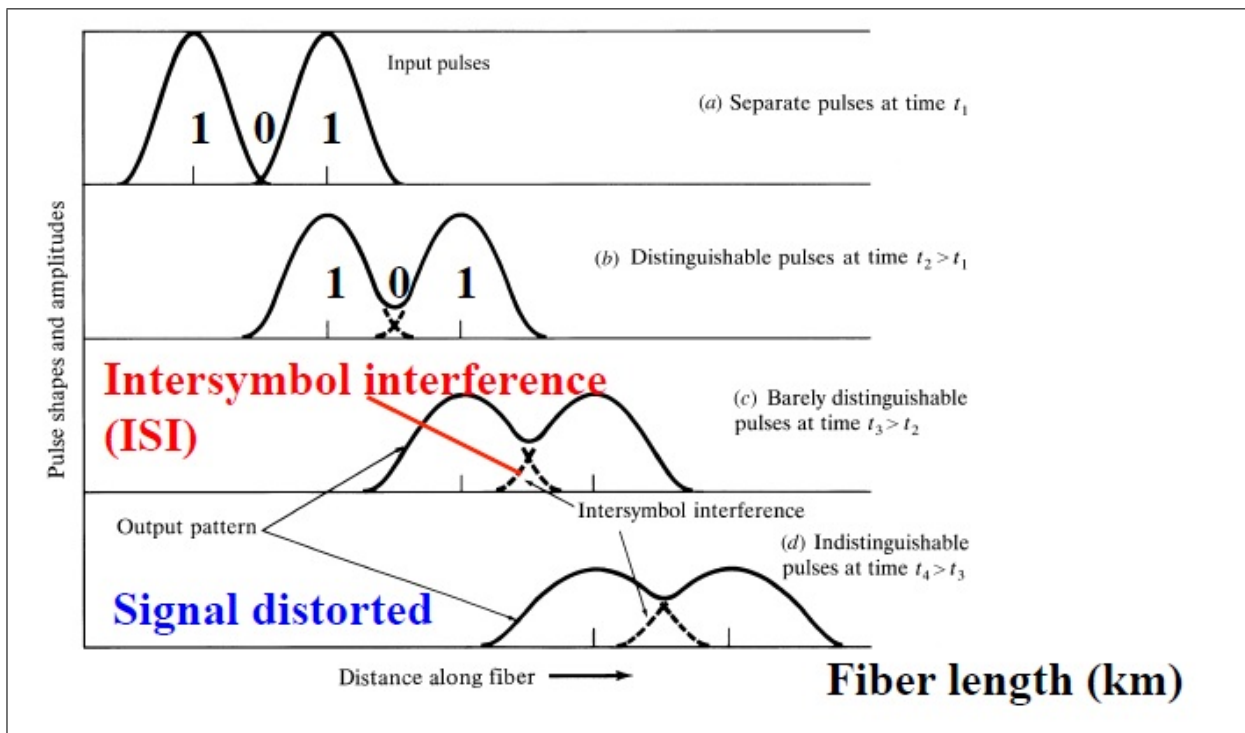

(b)

Figure 3: Illustration of fiber dispersion and the pulse ISI, a) fiber dispersion, b) pulse ISI

The chromatic dispersion in fiber results in pulse broadening and degrades transmission quality, limiting the distance over which a digital signal can travel without requiring regeneration or compensation. The maximum length of a link before it is affected by chromatic dispersion is commonly calculated using the following equation for Dense Wavelength Division Multiplexing DWDM systems employing Distributed Feed Back Laser DFB lasers:

$$n^2 = \frac{104,00}{CD} * B^2 \tag{3.10}$$

L denotes the link distance in kilometers, CD denotes the chromatic dispersion in picoseconds per (nm * km), and B denotes the bit rate in gigabits per second. Figure 4 depicts a universal optical communication scheme that includes an optical transmitter that consists of an optical origin, a

modulator, a data source, an NRZ driver, a fiber optic that serves as a communication channel, and an optical receiver that consists of a PIN. This scheme is constructed using an optical simulation package, as well as the results obtained using this simulator program.

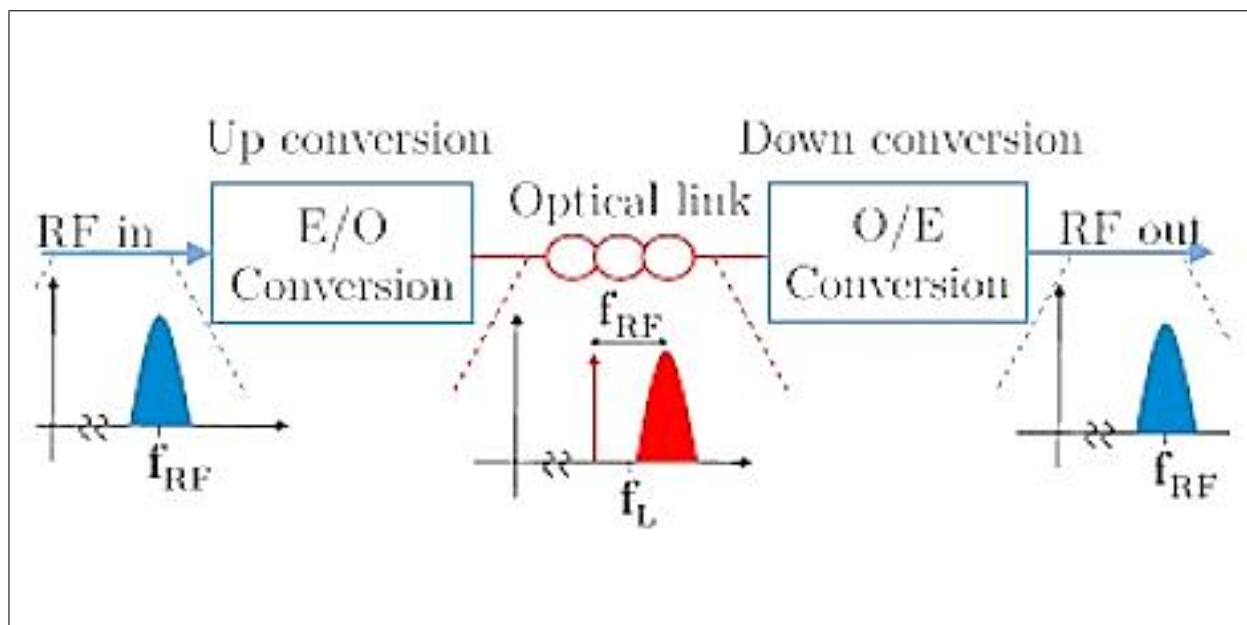
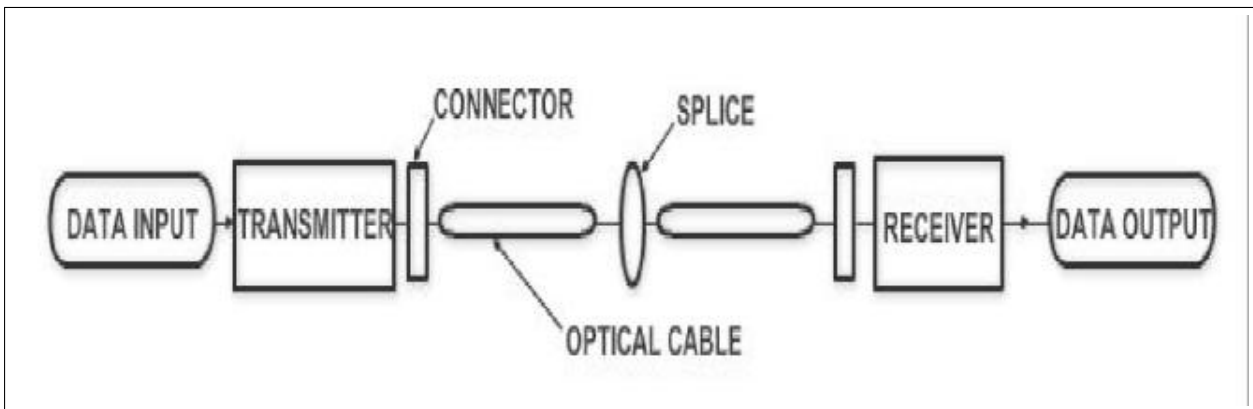

Figure 4: Single channel optical communication.

4. Simulation Results and Discussions

In this research, the optical fiber cable has been theoretically designed, modeled and simulated using MatLab17b simulation program. Two models of fiber optics cables have been considered, the single mode SM as well the multimode MM schemes. Since, “optical fiber” is in charged for data transfer. At the time that transmission and reception operation of the signal will be corrupted also distorted due to (i) distortion in the system and (ii) noise introduced in the system.

The imported noise stands for an undesirable energy, commonly of a random style as well it might be produced by different sources. Also, the expand in transportation distance produced an increment of an optical power loss passing through “optical fiber” in communication scheme. The noise as well

as the distortion effects have been modeled also simulated in the program using MatLab17b robust packages.

Two different types of wavelengths were considered in this simulation for the purpose of transferring data from one location to another.

When data is transferred from one point to another using the wavelength (850nm), the 1310nm and 1550nm types are used. It has been demonstrated that utilizing these wavelengths results in lower losses for the two fiber types SM and MM. Additionally, there was less loss with SM fiber than with MM fiber [8]

Where the program code for this simulation was written and it was executed correctly and properly as well the results shown in the figure 5 below were shown, where this figure shows the readings of the bit error rate (BER) versus bandwidth of the channel of the simulated fiber optic cable, which represents here the leadership of theoretical and practical readings as well as the effect of adding noise, fading, and interference to this program.

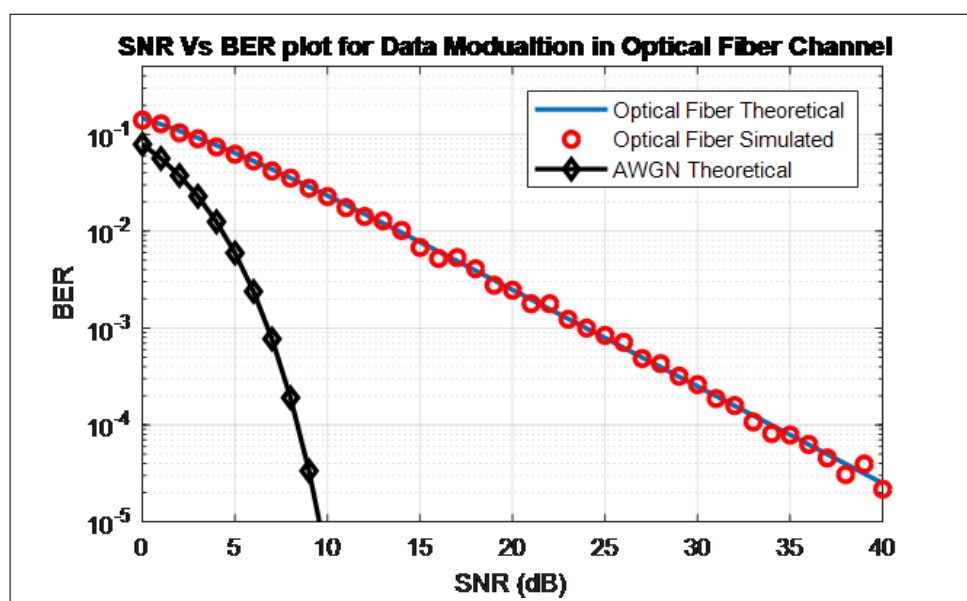

Figure 5: Results of the Fiber Optical Cable BER.

Where we notice that the blueprint and curve in blue represents the behavior of the work and the characteristics of the cable with the frequencies that can be received by this complete theoretical broadcaster theoretically as for the special chart red points it represents the characteristics of my behavior of this cable with the frequencies and with its channel hours in the form of simulation or in a practical way As for the diagram that appears in black, it represents the behavior of this keyboard, with its characteristics, with the bandwidth, and the channel will not continue through the entry of noise and interference to this cable.

The outcomes gotten from utilizing reenactment program in this work, are demonstrated and introduced vividly in figures. Figure 6 explains the ascent time versus information rate at explicit fiber optic length over fiber spine. This figure unmistakably shows the diminishing of the piece pace of connection because of increment the ascent time so these outcomes to diminish in data transmission channel limit. Along with the lines, we should diminish the general ascent time to communicate signal at huge information rate reach to 40Gbps and lengthier channel length, see table 1.

Now, concerning the evaluation of other cable parameters for this research, the optical fiber cable has been theoretically designed, modeled and simulated using MatLab17b simulation program. Two

Table 1: Time response for NRZ and RZ code under diverse data rates

R_b (NRZ) nbps	7.0681	4.9530	1.7119	1.0409	1.0007	1
R_b (RZ) nbps	4.0341	2.9765	1.3560	1.0204	1.0004	1
Rise Time sec	1	2	4	6	8	10

models of fiber optics cables have been considered, the single mode SM as well the multimode MM schemes. Since optical fiber is in charged for data transfer. At the time, that transmission and reception operation of the signal will be corrupted also distorted due to (i) distortion in the system and (ii) noise in the system. The imported noise is an undesirable energy, commonly of a random style as well it might be produced by different sources. Also, the expand in transportation distance produced an increment of an optical power loss passing through “optical fiber” in communication scheme. The noise as well as the distortion effects have been modeled also simulated in the program using MatLab17b robust packages.

Two different types of wavelengths were considered in this simulation to transfer data from one point to another. When the wavelength (850nm) is used to transfer data from one location to another, the 1310nm and 1550nm types are used. It has been demonstrated that utilizing these wavelengths results in lower losses for the two types of fiber, SM and MM. Additionally, SM fiber had a lower loss than MM fiber [22] Figures 7-9 illustrate the relationship between SNR, BER, and Quality factor and the number of defects in optical fiber.

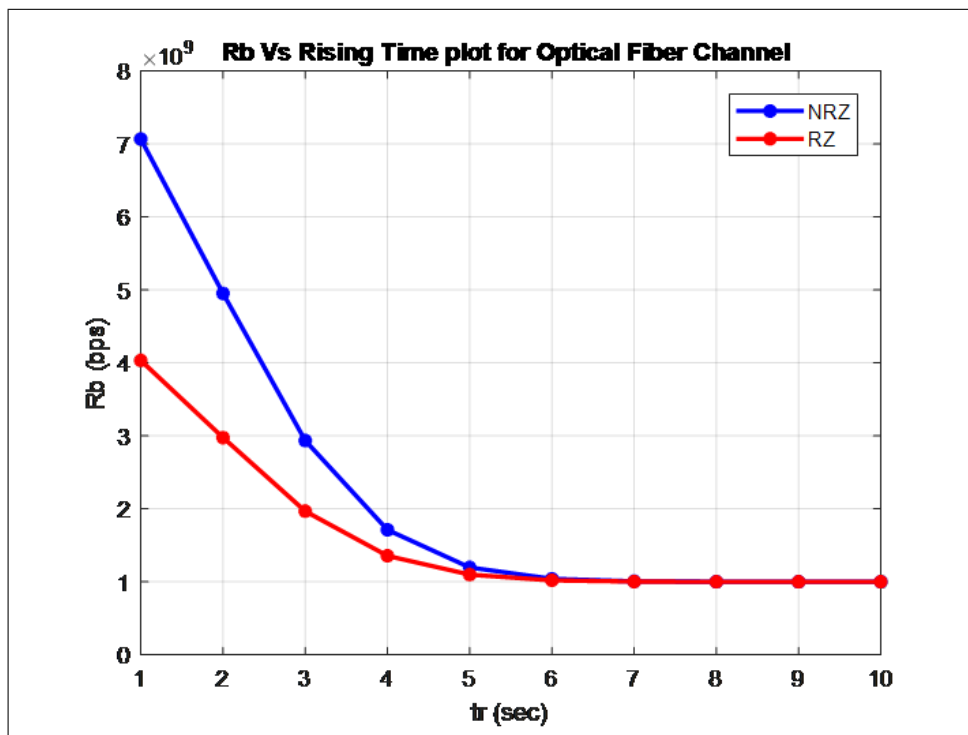

Figure 6: Rise time vs. Data rate at NRZ and RZ coding.

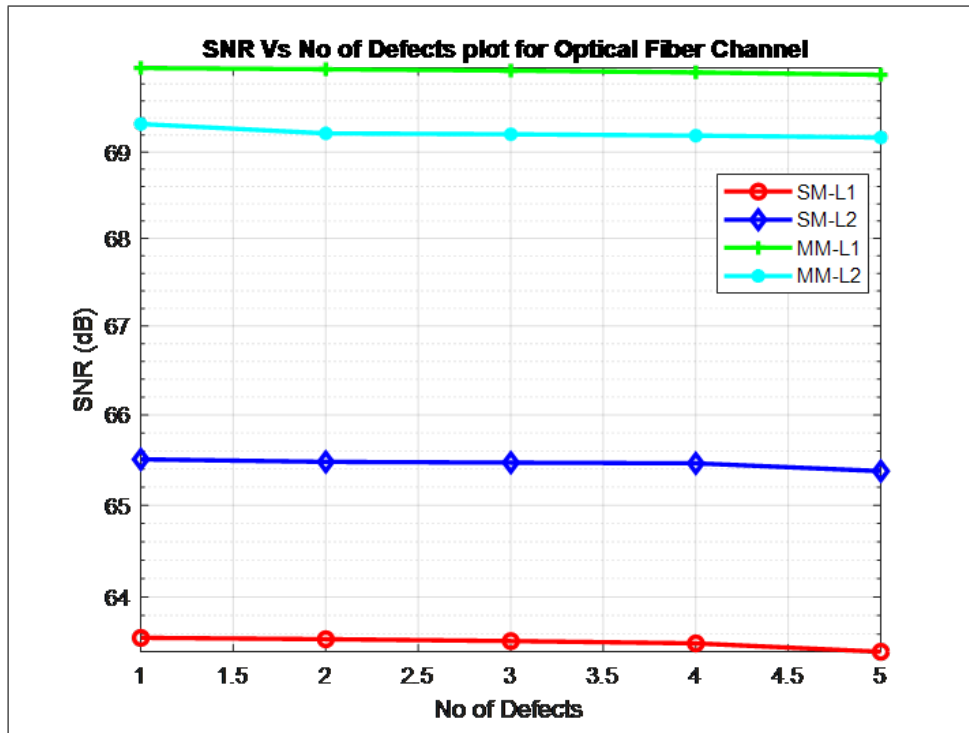

Figure 7: Results of SNR Vs. No of defects in the simulated Fiber Optical Cable.

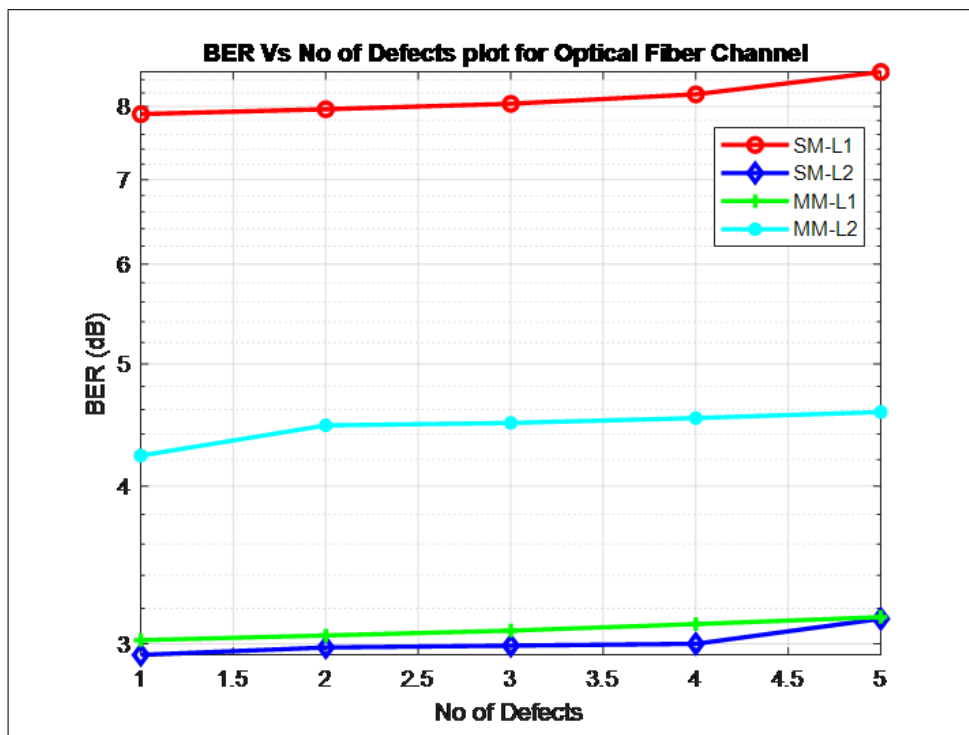

Figure 8: Results of BER Vs No of defects in the simulated Fiber Optical Cable.

Also, the transmitted power of the transmitted signal has been calculated for various values of fiber cable lengths as illustrated in Figure 10 below.

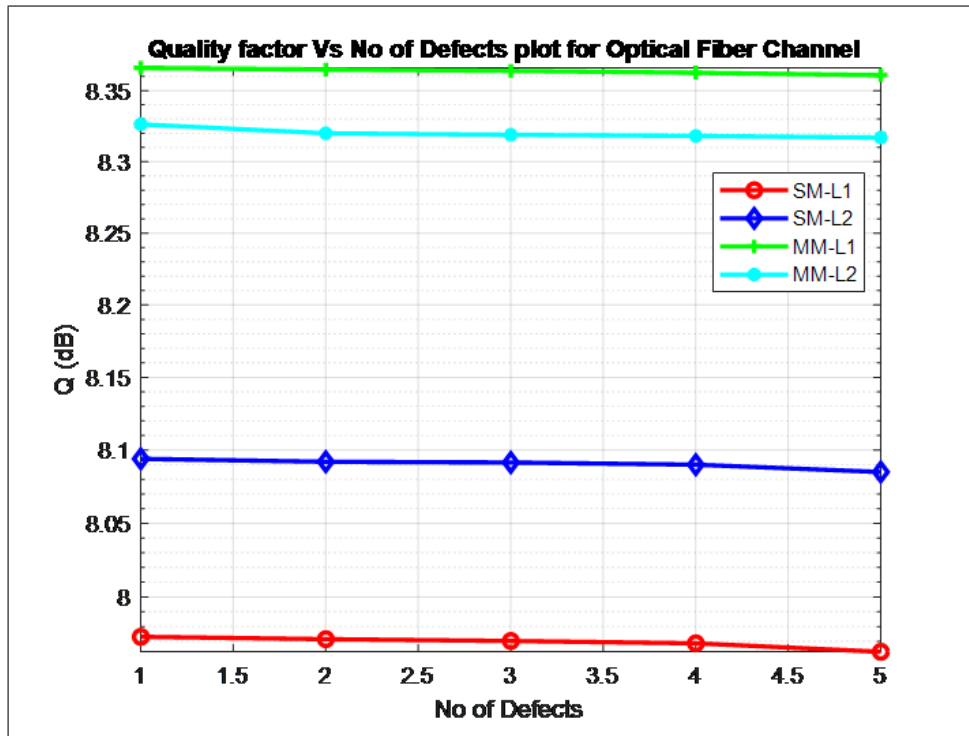

Figure 9: Results of Quality factor Vs No of defects in the simulated Fiber Optical Cable.

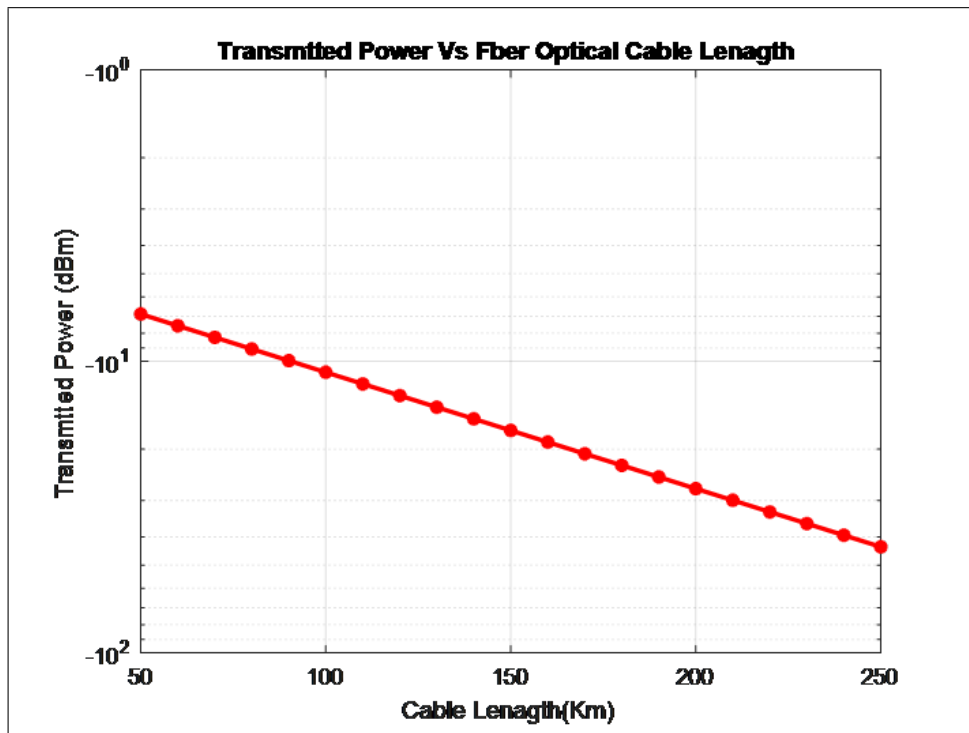

Figure 10: Results of P_{Tx} Vs. cable length in the simulated Fiber Optical Cable.

It is clear from the above figure that, the transmitted power of the simulated fiber optics cable is inversely proportional with its length. By other words, as the cable length increased we have to

increase the power required for data transmission since this power will degrade with cable length. Finally, the Bit Error Rate BER has been computed with wide range of channel bandwidth capacity or bit rate and plotted in Figure 11. In this figure, it is shown that the BER of the transmitted data will increased when these data are transmitted at high rate or as the number of transmitted bits has been increased. This is actually very logical, since errors and ambiguity in data occur when the data number becomes more and increased due to the increase of data collisions and interference during transmission.

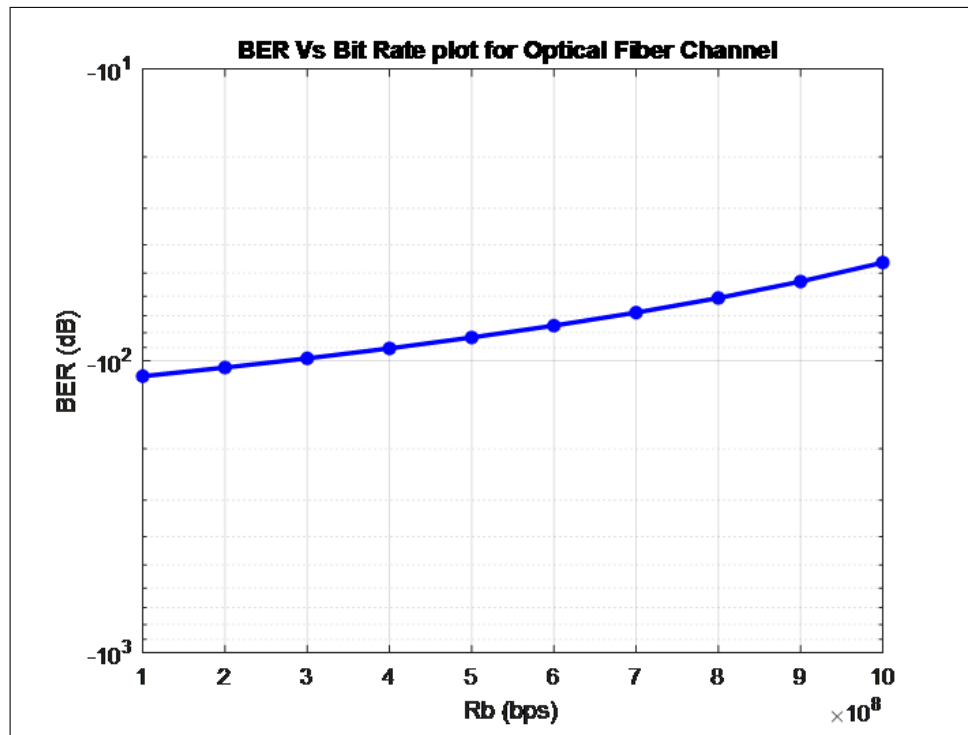

Figure 11: Results of BER Vs. Bit rate in the simulated Fiber Optical Cable.

5. Conclusions & Future Trends

The results of this study show that the fiber dispersion, transmitter, indicator reaction times, and phantom width of the light source all play important roles in system information transmission financial plans. Because dissipation restricts the highest piece rate that can be employed with strands, heartbeat dispersion in fiber should be handled to ensure that the structure could send signals at the necessary rate. Both single-channel and multi-channel systems require disaster spending plans and transmission capacity, which are essential components. In addition to the piece rate, the power and rising time monetary arrangement is employed to construct a realistic theory of the transmission distance. In order to get the best piece bungle rate, we also need adequate power or light to bypass all optical transmission problems and convey sufficient light to the beneficiary. Single channel plan processes can also be applied to each reroute in a multi-recurrence system. Spectral filter using fractal topologies based on a transmission spectrum of frequencies can be investigated as future trend in this study [14, 15]

References

- [1] S. J. Alam, M. R. Alam, G. Hu and M. Z. Mehrab, *Bit error rate optimization in fiber optic communications*, Int. J. Mach. Learn. Comput., 1(5) (2011) 435 .
- [2] S. H. Alnajjar, M. F. A. Malek and M. S. Razalli, *A novel approach evaluation for enhancing networks*, Procedia Eng. , 53(2013) 497-503.
- [3] L. Cohen, *Comparison of single-mode fiber dispersion measurement techniques*, J. lightwave Technol., 3(5)(1985) 958-966.
- [4] I. B. Djordjevic , *Advanced optical and wireless communications systems*, Heidelberg, Springer, 2018.
- [5] R. Hainberger, T. Hoshida, S. Watanabe and H. Onaka, *BER estimation in optical fiber transmission systems employing all-optical 2R regenerators* , J. Lightwave Technol., 22(3) 746–754 (2004).
- [6] J. Hecht, *Understanding fiber optics*, Jeff Hecht, 2015.
- [7] G. Hill, *The cable and telecommunications professionals' reference: transport networks(Vol.2)* ,Taylor and Francis, 2008.
- [8] T. Ivaniga and P. Ivaniga, *Evaluation of the bit error rate and Q-factor in optical networks*, IOSR J. Electron. Commun. Eng. , 9(6)(2014) 01-03.
- [9] G. Keiser, *Optical fiber communications*, Wiley India, 2011.
- [10] R. Kone and H. Zhou, *End-to-end availability analysis of physical network*, The Fourth Int. Conf. Comput. Inf. Technol., 2004. CIT'04.,2004, pp.1401- 1405.
- [11] C. F. Lam (Ed.), *Passive optical networks: principles and practice*, Elsevier, 2011.
- [12] P. Lecoy, *Fiber-Optic Communications* , John Wiley & Sons, 2013.
- [13] X. Li, J. Yu, Z. Dong, and N. Chi, *Photonics millimeter-wave generation in the E-band and bidirectional transmission*, IEEE Photonics J., 5(1)(2013) 7900107-7900107.
- [14] Y. S. Mezaal and H. T. Eyyuboglu, *Investigation of new microstrip bandpass filter based on patch resonator with geometrical fractal slot*, PloS one, 11(4)(2016), e0152615.
- [15] Y. S. Mezaal, H. T. Eyyuboglu and J. K. Ali, *A novel design of two loosely coupled bandpass filters based on Hilbert-zz resonator with higher harmonic suppression*, Third Int. Conf. Adv. Comput. Commun. Technol. (ACCT),(2013, April) pp. 343-347 IEEE.
- [16] M. J. O'Mahony, C. Politi, D. Klonidis, R. Nejabati and D. Simeonidou, *Future Optical Networks* , J. Lightwave Technol., 24(12) (2006) 4684-4696.
- [17] S. K. Raghuvanshi ,V. Palodiya, A. Kumar and S. Kumar, *Experimental characterization of fiber optic communication link for digital transmission system* , ICTACT J. Commun. Technol., 5(10), 868-876.
- [18] M. F. M. Salleh and Z. Zakaria, *Effect of bending optical fibre on bend loss over a long period of time* , ARPN J. Eng. Appl. Sci., 10(16) (2015) 6732-6736.
- [19] N. Sangeetha , J. Santhiya and M. Sofia, *Bend loss in large core multimode optical fiber beam delivery system* , Int. J. Adv. Res. Comput. Commun. Eng., 4 (5) (2015).
- [20] J.M. Simmons, *Optical network design and planning*, Springer, 2014 .
- [21] S. Singh , *Simulation and Optimization of Optical Amplifiers in Optical Communication Networks* , A Thesis of doctor of philosophy, Department of Electronics and Communication Engineering ,Thapar University, Patiala (Punjab) India, October, 2007.
- [22] X. Wei, X. Liu and C. Xu, *Q factor in numerical simulations of DPSK with optical delay demodulation* , arXiv preprint physics/0304002, 2003.