

Optimizing the performance reliability of diagnostic equipment and wearable sensors and medical devices in IOMT

Tahereh Moein, Mohammad Ali Keramati*, Hossein Moinzad

Department of Information Technology, Central Tehran Branch, Islamic Azad University, Tehran, Iran

(Communicated by Seyed Hossein Siadati)

Abstract

Today, healthcare has become an essential part of life, and in the meantime, the Internet of Things (IoT) is widely recognized as a potential solution to reduce the pressure on healthcare systems, which, by its very nature, optimizes the ability. The performance reliability of diagnostic equipment, wearable sensors and medical equipment in the Internet environment has also been the focus of many recent researches. Therefore, in this research, using neural networks (LSTM), an algorithm for optimal diagnosis of medical equipment was proposed and its efficiency was evaluated. The results showed that the LSTM architecture together with the Dropout layer and the Tanh activation function showed better performance and had the lowest average absolute value of error (MAPE) as well as the root mean square error (RMSE) in determining the abnormalities of medical equipment. The accuracy of the proposed method shows 96% and the accuracy, recall and evaluation criteria of the model are 95% respectively. 94.5 and 97% have been calculated, which fully shows the suitability of the proposed algorithm in predicting anomalies and, of course, its suitability for improving the assurance of the proper functioning of medical equipment and sensors.

Keywords: diagnostic equipment, medical equipment, wearable sensors, medical IoT, neural networks, LSTM algorithm

2020 MSC: 92C47, 62P10, 68M11

1 Introduction

Healthcare has become an essential part of life today. The continuous ageing of the population and the resulting increase in chronic diseases puts significant pressure on modern healthcare systems and has greatly increased the demand for resources, from medicine to hospital beds, doctors and nurses [17]. It is clear that, given the current circumstances, a solution is needed to reduce the pressure on healthcare systems while continuing to provide high-quality care to at-risk patients.

The Internet of Things (IoT) has been widely recognized as a potential solution to reduce pressure on healthcare systems and has therefore been the focus of much recent research [11]. A significant part of this research focuses on monitoring patients with specific conditions such as diabetes [5] or Parkinson's disease, and another part of the research seeks specific goals such as assisting rehabilitation through continuous monitoring of patient progress, and emergency health care. and finally, optimizing the reliability of the performance of diagnostic equipment and wearable

*Corresponding author

Email addresses: taherehmoein@gmail.com (Tahereh Moein), moinzad@iauctb.ac.ir (Mohammad Ali Keramati), mohammadalikeramati@yahoo.com (Hossein Moinzad)

sensors and medical equipment in the context of the Internet of Medical Things, although it must be acknowledged that this has not yet been widely researched.

Remote health monitoring systems are an important component of the Internet of Things (IoT) concept. Internet of Things technologies used in healthcare are called Medical Internet of Things (IoMT). IoMT can be defined as a combination of medical devices and applications that can be connected to healthcare IT systems using network technologies. The goal of IoMT is to reduce healthcare costs and increase the quality of life of people who need health monitoring. The concept of IoMT is based on the principle of interoperability of various medical devices and circuits with various software platforms, such as network technologies such as Wi-Fi, G4, and G5, sensors and operators designed for physiological data such as breathing rate, heart rhythm, oxygen [29].

In principle, the use of wearable medical devices, apart from their use to monitor vital signs, but also to monitor patients with chronic diseases and cognitive disorders such as Parkinson's, diabetes, Alzheimer's, asthma and epilepsy, has expanded a lot. These devices have proven to be valuable and effective assets for both patients and healthcare providers, as they help reduce problems such as the growing number of patients in hospitals, increased waiting times for treatment, and overstaying of patients in healthcare facilities. The need for the presence of the required number of nurses and doctors has had a positive effect and has reduced health care costs.

Wearable medical devices also enable greater mobility for the subject being monitored and continuously collect and transmit vital physiological data to healthcare providers. This feature may be especially useful for situations where there is a need for long-term monitoring of the patient's recovery after leaving the hospital or evaluating the impact of rehabilitation of patients [22].

Despite the numerous and significant advantages and possibilities that this technology offers to the field of treatment and medicine, these devices are associated with a range of challenges and disadvantages, from poor reliability to high susceptibility to post-deployment security attacks. Body wireless sensor network sensors are subject to hardware and software problems, such as parts failure, sensor calibration, battery discharge, or moving and changing the location of the sensor. Sensor data itself can be both unreliable and inaccurate. This is due to cases where there are limitations in hardware resources such as reduced processing power, memory limitations, lack of energy resources and transmission range. At the time of aggregating sensor data and transferring them to storage servers, there is a possibility of various types of irregularities such as interference, noise, incorrect placement of sensors, sweating of patients, and reduction or depletion of energy sources.

Therefore, the occurrence of these problems and defects can lead to unexpected results, false alarms, faulty diagnoses, and finally to a decrease in public trust and confidence in these systems, and finally, the health and lives of patients face irreparable risks. Therefore, solving these important challenges that require increasing accuracy in identifying and optimizing their performance reliability should be in the center of attention [22]. In this study, by identifying the key components of an Internet of Things health care system, a model of neural networks to identify abnormalities to optimize the diagnosis of abnormalities and the reliability of the performance of diagnostic equipment and wearable sensors and medical equipment and in the field of IOMT is proposed. which can be applied to some health care systems based on the Internet of Things in the medical field.

1.1 Theoretical foundations and research background

1.1.1 Healthcare and internet of things

Rapid advances in science and technology make it possible to act faster and more effectively in protecting health and fighting today's diseases. The health sector is one of the areas that benefit the most from the perspective of the fourth industrial revolution (Industry 4.0) and Internet of Things (IoT) technology, which include very important concepts such as sensors, data collection, production of digital products and devices, And finally, it incorporates the processing and storage of data flowing from objects, which is based on connecting systems to different networks and establishing communication through various interfaces. Today, the Internet of Things allows physical objects to see each other with the identity of a computer or medical product and share their information so that they can make decisions.

The field of health and treatment in the field of medical informatics uses the most up-to-date technologies such as computer systems and industrial servers, database and big data management systems, data security, business intelligence and performance management, cloud systems. The development of technologies such as the Internet of Things, cloud computing, wireless broadband connections and decision support systems enable health professionals to provide preventive health services, implement rapid diagnosis and effective treatment, and efficiently maintain post-treatment services.

The new technology trend called the Internet of Medical Things (IoMT), in the activities of health institutions, in the fields of public health and in the field of personal health, collects various data through various sensors without the need for human intervention. Therefore, it is based on this principle that they can be transferred from various gateways through pre-processing from smart devices and analyzed on the server and transferred from one server to another in a very short period of time.

The Internet of Things in the field of health and health and the transformation of traditional systems into smart ones with the support of basic technologies such as devices compatible with the Internet of Things technology, communication protocols, sensor networks, Internet protocols, creates the possibility of many practical applications in the field of health [15].

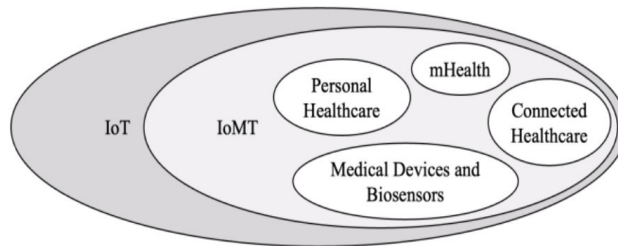

Figure 1: IoMT and healthcare-related subsectors as major subsectors of the Internet of Things

As shown in Figure 1, IoMT is a major subset of the Internet of Things (IoT), which focuses on healthcare as one of the fundamental pillars of human needs and is expected to generate billions of dollars in revenue [19]. IoMT covers several aspects, namely: 1) medical sensors and devices that collect biomedical data from simple body sensors to more complex and specialized surgical instruments 2) communication networks and channels Safe between patients and medical staff as well as various medical facilities and resources 3) Distributed information technology systems to facilitate the creation, access and maintenance of electronic patient health records 4) Health-oriented services and interactive applications [26].

Recent advances in micro-electromechanical systems (MEMS) and sensor technologies have led to the development of a wide variety of smart body sensors, implantable biosensors, wearable devices, and monitoring devices. IoMT, with these advances and the next generation of wireless technologies, big data and cloud computing, has created a paradigm shift and made safe, intelligent healthcare systems more accessible and efficient [9].

1.1.2 The technology used and how the internet of medical things works

The development and expansion of the Internet in the environment has paved the way for the improvement of IoMT applications and systems in our daily life. Most IoMT systems work at the following core layers, which connect different technologies, devices, sensors, and systems through electro-electronic, wired, or wireless connectivity. The structure and function of each layer is explained in Figure 2.

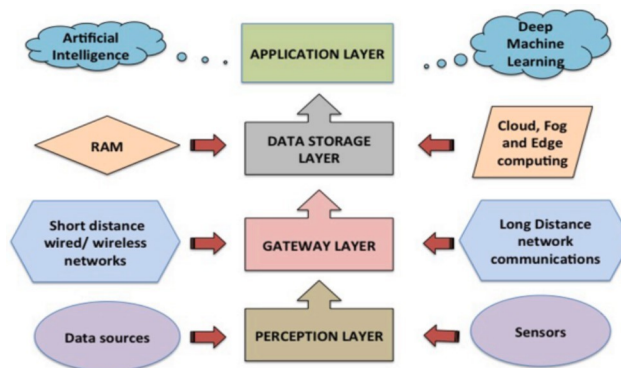

Figure 2: Different layers involved in the IoMT framework

The lowest layer of the IoMT, which is designated as the perception layer, includes data sources, such as smart objects, health monitoring devices, mobile applications, which interact with sensors such as infrared sensors, medical

sensors, smart device sensors, frequency identification cameras. Radio (RFID) and Global Positioning System (GPS) are integrated. Sensor systems perceive changes in an environment and detect object, location, magnitude, etc., and convert the information into digital signals with the help of strong, wired or wireless network transmission infrastructures that act as high-performance transmission media. These can also remember and store data for future reference [24].

As mentioned before, sensors need to connect to gateways that are established through networks that store information locally or centrally. Communication can be in different frequencies and can be short-range such as RFID, wireless sensor networks, Bluetooth, Zigbee, low-power Wi-Fi and mobile communication or long-range such as cloud computing, blockchain, etc. Networks can be personal area networks (PANs) such as ZigBee, Bluetooth and ultra-wideband (UWB) or local area networks (LANs), Ethernet connections, and Wi-Fi. In addition, Wide Area Network (WAN) such as Global System for Mobile Communications (GSM) which do not require connectivity but use servers/applications and Wireless Sensor Networks (WSN) which have the capability of placing a large number of sensor nodes which in some cases are useful. Sensors that require low power connection and low data rate can also be used. High-frequency fourth-generation (G4) and evolving fifth-generation (G5) cellular networks have also become very popular because they are reliable in connecting multiple devices simultaneously. The enormous potential of communication can increase the growth of IoMT applications for healthcare and emerge as its main driver [14].

The IoMT in processing vast raw data to extract relevant information requires tools that form the management service or application support layer that can work at a rapid pace using analytics, security controls, process modeling, and device management. This management layer/application provides user management, data management and data analysis. Web servers and their gateways such as Apache 2, Flask (Python web server gateway interface) provide scalability and flexibility. Databases like MongoDB (NoSQL database) provide flexibility in the types of data stored. To establish a secure connection, the Sockets Secure Layer API (SSL; API) is used. Communication data can be stored locally/decentralized (fog or edge) or centrally in a cloud server. Cloud-based centralized computing is highly accurate yet flexible and scalable. IoMT devices support the collection of data such as compact electronic medical records (EMR) from patient portals and smartphone applications and transfer them to a cloud server to support decision making of treatment strategies [7].

The function of the last and most important layer of the program is to interpret data and provide specific application services. The application layer uses artificial intelligence (AI) and deep machine learning to understand EMR data and monitor trends and changes in the collected data through various daily/weekly charts to make decisions about diagnosis and/or treatment possibilities. Therefore, apart from image analysis, text recognition and language processing include health care applications such as drug activity design, risk prediction and gene mutation expression, medical results, management suggestion in diabetes and mental health, and predicting the progress of congestive heart failure, cardiac arrhythmia, Bone disease, Alzheimer's disease and benign and malignant tumor. and... also does [23].

1.1.3 Identification system with radio waves and internet of medical objects

The radio frequency identification system (RFID) is a wireless identification system that is capable of exchanging data by communicating information between a tag that is connected to a product, object, card, etc. and is a reader. RFID systems use electronic and electromagnetic signals to read and write data without contact. Basically, any system that is able to read and recognize the information of people or goods is called an identification system. Basically, automatic identification systems are used when we want to automatically track living/inanimate devices or assets in an environment. automatic identification; This is a general definition for technologies that enable automatic identification of living/inanimate objects. RFID technology in these systems; It is preferred in medical IoT applications due to its low energy requirement and higher data storage capacity compared to other identification systems. From babies to patients, their descriptive information can be loaded onto a card with an RFID tag. In this case, time and resource consumption for various processes are minimized and human-caused data entry errors are prevented and asset tracking becomes possible in real time. RFID is a technology that enables the identification of objects with the help of radio waves. This system consists of tags and RFID readers. The RFID tag contains identification information in a microchip and an antenna connected to this chip. The antenna transmits the information contained in the chip to the reader. The reader transmits this information received from the RFID tag to the control system. The diagram below shows how this technology works in the Internet of Things [4].

1.1.4 Parallel fog, edge and cloud computing

Basically, parallel processing techniques form the basis of distributed computing techniques, which include paradigms such as grid computing, cloud computing, fog and edge computing. The IoMT and its applications involving real-time

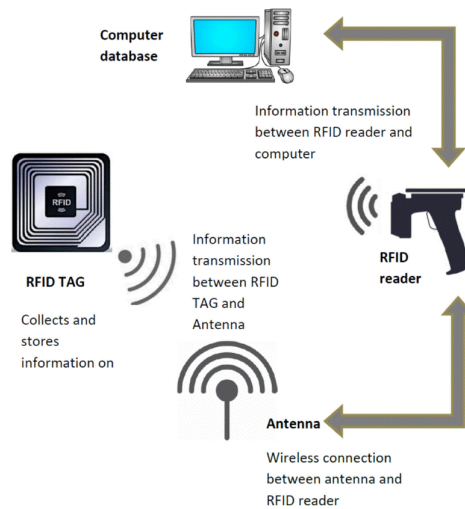

Figure 3: The main components of RFID

interactions are an emerging source of big data, and therefore it becomes very important to determine and separate data that should be kept locally from data that should be shared among cloud servers.

Today, the data processing architecture for IoMT systems has shifted from centralized cloud computing to distributed fog computing technology. In short, cloud computing creates a hierarchy of layers between the hardware components and the cloud server (kernel level). This reduces the amount of data stored on cloud servers and, as a result, reduces network bandwidth and response time in cloud computing and subsequently minimizes internet and network delays. Fog computing also increases data security, as data stays locally at the edge and not in the cloud. Thus, instead of placing the data in the cloud, edge computing maintains the data near the edge of the device's own network or by the local server where the data was generated. Edge computing minimizes delays and provides immediate response to smart devices by accelerating data flow when processing real-time IoMT data. Considering the impending threats to data integrity and security in the cloud and fog, edge computing has emerged as a secure and robust paradigm.

In this regard, Ahangar et al. [1] in a study developed an IoMT-based health care system for monitoring and predicting the spread of COVID-19, which includes a four-level architecture - data collection, information classification, exploration and extraction, and Finally, modeling is prediction and decision. They observed that the results of the fog-based paradigm improved significantly in terms of classification efficiency, predictability, and reliability. Pham et al. [18] investigated the "cloud-based smart home environment (CoSHE)" for efficient monitoring and health assessment at home, which includes home setup, private cloud infrastructure, wearable unit, and home service robot. In this study, they emphasized It has been reported that the textual information processed together with the sensor data by the smart home gateway provides further processing to the private cloud and access to the recorded data for caregivers. Cui et al. [6] in another study, a health monitoring framework. Using cloud computing, IoMT devices and connected sensors were created to monitor the patient's heart rate, oxygen saturation percentage, body temperature, and eye movement.

1.1.5 Challenges of IoT and IoMT

In the field of medicine, there are challenges for IoT that are briefly presented in the table below. It is natural that if these challenges are resolved in the field of IoT, the standard of IoT in the field of IoMT medical care will definitely be improved and the level of confidence in the performance and efficiency of diagnostic, medical equipment and wearable sensors will also increase. Therefore, solving these problems can provide more reliable and better services in the field of healthcare and medicine [13]:

Therefore, despite the fact that in recent years, IoMT has made significant progress, however, before mass adoption and their full capacity, some challenges should be addressed in future research and studies. to be The major challenges in this area are mainly data privacy and security, data management, scalability and upgradeability, regulation, interoperability and affordability of IoMT.

Table 1: IoT challenges in the field of medicine

RESEARCH	Current challenges in the field of medicine	reference
1	- Device diversity management	site TCS
2	- Scale, data volume and performance	yuan Ge et al (2016)
3	- Flexibility and evolution of programs	Andriopoulou et al (2017)
4	- Hardware implementation and design	Matar et al (2017)
5	- Optimization issues	Singh (2016)
6	- Security challenge	Xu et al (2015)
7	-Technical challenges: modeling the relationship between acquired measurements and diseases	His et al (2014)
8	Artificial intelligence in medical care	Tsoutsourasm et al (2016)
9	- Predictability of the system	Chavan et al (2016)

1.1.6 Review of experimental studies

The existing studies in the field of IoMT are accelerating day by day, because it is trying to reduce health costs and the workload of health-medical personnel. In IoMT architectures, there are devices with different structures and tasks that can work especially in health data collection. These equipment can measure different measurements such as body temperature, pulse, ECG, oxygen level, etc. While they each have different equipment, they may need to be in the same environment and work together. For this reason, there is a need for technology and architectures that can use the same communication resources. In addition to the listed technical points, there is another expectation that people who are supervised and equipped with this equipment, can easily perform their normal life movements. This expectation reveals the necessity of communication of wireless and other Internet of Things devices. In the following, some of the recent studies of IoMT are mentioned.

In a study, Rahaim et al. [20] proposed a meaning-based and context-sensitive architecture to increase the reliability of patient monitoring. In this study, in order to evaluate the applied IoMT system, the case study of gestational diabetes was emphasized and investigated. In another study, the current and potential threats to the IoMT network environment by the main security structures such as confidentiality, integrity, non-repudiation, authentication, authorization and the usability of the target of these threats have been investigated and finally classified by researchers [16]. In another study, Avan et al [3], developed a system that predicts malicious nodes and by removing these nodes, ensures the continuity and proper functioning of the network. In another research, Tamilarasu et al [28] designed a new intrusion detection system based on mobile agent to secure the medical equipment network and optimize the attack detection capability. The system proposed by these researchers uses machine learning and regression algorithms to identify hierarchical intrusions and anomalies. In another study, an energy-efficient fogcloud architecture of medical Internet of Things was proposed to optimize energy consumption. In the proposed architecture, biosensors with Bluetooth have been used, and it has been stated that the Bluetooth technology used is energy efficient and optimal, and at the same time, it also helps to activate the patient's sleeping and waking states [27]. In another study, Al-Turajman et al [2] proposed a system to increase performance reliability and handle big data distribution problems in cloud-based IoT environments in their study, considering uncertainty factors. They evaluated the performance of the system using two techniques based on artificial intelligence (AI) namely Genetic Algorithm (GA) and Simulated Annealing Algorithm (SAA) in a centralized and distributed manner and emphasized the efficiency of this system.

2 Research methodology

2.1 Research method and data collection

In this research, based on mathematical models and using the ability of LSTM deep neural network algorithm architectures, which are a developed example of recurrent neural networks (RNN) that are designed to avoid the long-term dependence problem in the RNN network. It is used to detect abnormalities and optimize the performance of medical equipment and sensors. The data and information needed for this study are collected from the library and document method. Therefore, by studying scientific texts and related articles, the literature and theoretical foundations of the research will be collected using surveys. In the second stage, valid medical datasets in the field of bioinformatics, such as Physio net, are used to train the desired algorithm. The proposed method in this study consists of seven main steps as follows, which are: *a*-determining the required critical data sets, *b*-creating a data transfer layer using the software programming interface, *c*-collecting and storing data, *T*- Sensors data pre-processing, *C*- Data evaluation, *C*-Analyzing the possible abnormality of the data, *C*-Algorithm evaluation.

The input data in this study are entered into the LSTM network in order to predict each activity to the corresponding class. Then the modeling and simulation of the proposed method, based on the LSTM algorithm, using machine learning libraries and using the Python language, the implementation and the results of this research are analyzed and evaluated in the prepared artificial intelligence software.

2.2 Criteria for evaluating the algorithm

In deep neural networks, the entire network is trained using non-linear functions and necessary layers. In this regard, accuracy and precision criteria are very important. These evaluation relations are presented in equations (2.1) and (2.2).

Accuracy criterion: This criterion shows how well the used model correctly predicts the output. By checking the accuracy criterion, you can find out whether the model is trained correctly or not and how it performs in general.

$$\text{Accuracy} = (\text{TP} + \text{TN}) / (\text{TP} + \text{FN} + \text{FP} + \text{TN}) \quad (2.1)$$

Correctness criterion: When the model predicts the result as positive, this criterion determines how true the result is. It is also called the sensitivity criterion.

$$\text{Precision} = \text{TP} / (\text{TP} + \text{FP}) \quad (2.2)$$

Table 2: How to obtain evaluation criteria

Predicted status \ real situation	True	False
	Positive	True-Positive
Negative	False-Negative	True-Negative

In addition to the two criteria mentioned above, two other criteria are also used as follows:

Recall criterion: When the False Negative value is high, the recall criterion is a suitable criterion. One of the most important parameters that is checked along with sensitivity is the recall criterion or property, which is also called the True Negative Rate. Specificity means the proportion of negative cases that the test correctly identifies as negative samples.

$$\text{Recall} = (\text{TPR}) = \text{TP} / (\text{TP} + \text{FN}) \quad (2.3)$$

Evaluation criterion: This is a suitable criterion for evaluating the accuracy of the test, which considers both recall and precision. The F1 criterion is one at best and zero at worst.

$$\text{F1score} = 2 * (\text{Recall} * \text{Precision}) / (\text{Recall} + \text{Precision}) \quad (2.4)$$

Long short-term memory (LSTM)

Long short-term memory (LSTM) is an artificial neural network used in the fields of artificial intelligence and deep learning. Unlike standard feedforward neural networks, LSTM has feedback connections. Such a recurrent neural network (RNN) can process not only single data points (such as images), but also entire sequences of data (such as speech or video). This characteristic makes LSTM networks ideal for processing and predicting data. For example, LSTM is applicable to tasks such as unsegmented, connected handwriting recognition, speech recognition, machine translation, speech activity detection robot control, video games, and healthcare. The name of LSTM refers to the analogy that a standard RNN has both “long-term memory” and “short-term memory”. The connection weights and biases in the network change once per episode of training, analogous to how physiological changes in synaptic strengths store long-term memories; the activation patterns in the network change once per time-step, analogous to how the moment-to-moment change in electric firing patterns in the brain store short-term memories. The LSTM architecture aims to provide a short-term memory for RNN that can last thousands of timesteps, thus “long short-term memory” [12, 21].

Figure 4 shows the structure of an LSTM network, which includes three input, output, and forgetting gates. The output of the LSTM network is connected to the input of the network and the input of the mentioned three gates. Different activation functions are used in each of the input, output and forget gates. Non-dotted joints including non-weighted joints and dotted joints are all weighted [8].

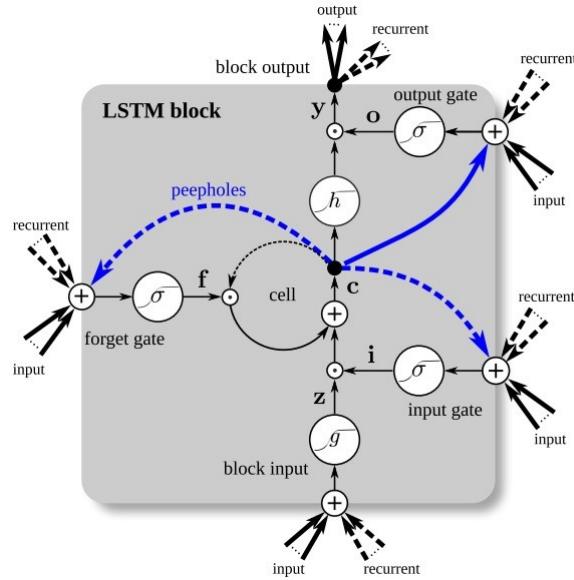

Figure 4: Architecture of an LSTM network

A common LSTM unit is composed of a cell, an input gate, an output gate and a forget gate. The cell remembers values over arbitrary time intervals and the three gates regulate the flow of information into and out of the cell. Forget gates decide what information to discard from a previous state by assigning a previous state, compared to a current input, a value between 0 and 1. A (rounded) value of 1 means to keep the information, and a value of 0 means to discard it. Input gates decide which pieces of new information to store in the current state, using the same system as forget gates. Output gates control which pieces of information in the current state to output by assigning a value from 0 to 1 to the information, considering the previous and current states. Selectively outputting relevant information from the current state allows the LSTM network to maintain useful, long-term dependencies to make predictions, both in current and future time-steps [12, 21].

LSTM networks are well-suited to classifying, processing and making predictions based on time series data, since there can be lags of unknown duration between important events in a time series. LSTMs were developed to deal with the vanishing gradient problem that can be encountered when training traditional RNNs. Relative insensitivity to gap length is an advantage of LSTM over RNNs, hidden Markov models and other sequence learning methods in numerous applications [25].

Variants

In the equations below, the lowercase variables represent vectors. Matrices W_q and U_q contain, respectively, the weights of the input and recurrent connections, where the subscript q can either be the input gate i , output gate o , the forget gate f or the memory cell c , depending on the activation being calculated. In this section, we are thus using a “vector notation”. So, for example, $c_t \in \mathbb{R}^h$ is not just one unit of one LSTM cell, but contains h LSTM cell’s units.

LSTM with a forget gate

The compact forms of the equations for the forward pass of an LSTM cell with a forget gate are:

$$\begin{aligned}
 f_t &= \sigma_g(W_f x_t + U_f h_{t-1} + b_f) \\
 i_t &= \sigma_g(W_i x_t + U_i h_{t-1} + b_i) \\
 o_t &= \sigma_g(W_o x_t + U_o h_{t-1} + b_o) \\
 \tilde{c}_t &= \sigma_c(W_c x_t + U_c h_{t-1} + b_c) \\
 c_t &= f_t \odot c_{t-1} + i_t \odot \tilde{c}_t \\
 h_t &= o_t \odot \sigma_h(c_t)
 \end{aligned}$$

where the initial values are $c_0 = 0$ and $h_0 = 0$ and the operator \odot denotes the Hadamard product (element-wise product). The subscript t indexes the time step.

Variables

- $x_t \in \mathbb{R}^d$: input vector to the LSTM unit
- $f_t \in (0, 1)^h$: forget gate's activation vector
- $i_t \in (0, 1)^h$: input/update gate's activation vector
- $o_t \in (0, 1)^h$: output gate's activation vector
- $h_t \in (-1, 1)^h$: hidden state vector also known as output vector of the LSTM unit
- $\tilde{c}_t \in (-1, 1)^h$: cell input activation vector
- $c_t \in \mathbb{R}^h$: cell state vector
- $W \in \mathbb{R}^{h \times d}$, $U \in \mathbb{R}^{h \times h}$ and $b \in \mathbb{R}^h$: weight matrices and bias vector parameters which need to be learned during training

where the superscripts d and h refer to the number of input features and number of hidden units, respectively.

Activation functions

- σ_g : sigmoid function.
- σ_c : hyperbolic tangent function.
- σ_h : hyperbolic tangent function or, as the peephole LSTM paper suggests, $\sigma_h(x) = x$.

Peephole LSTM

The figure on the right is a graphical representation of an LSTM unit with peephole connections (i.e. peephole LSTM). Peephole connections allow the gates to access the constant error carousel (CEC), whose activation is the cell state. h_{t-1} is not used, c_{t-1} is used instead in most places.

$$\begin{aligned}
 f_t &= \sigma_g(W_f x_t + U_f c_{t-1} + b_f) \\
 i_t &= \sigma_g(W_i x_t + U_i c_{t-1} + b_i) \\
 o_t &= \sigma_g(W_o x_t + U_o c_{t-1} + b_o) \\
 c_t &= f_t \odot c_{t-1} + i_t \odot \sigma_c(W_c x_t + b_c) \\
 h_t &= o_t \odot \sigma_h(c_t)
 \end{aligned}$$

Each of the gates can be thought as a “standard” neuron in a feed-forward (or multi-layer) neural network: that is, they compute an activation (using an activation function) of a weighted sum. i_t , o_t and f_t represent the activations of respectively the input, output and forget gates, at time step t .

The 3 exit arrows from the memory cell c to the 3 gates i , o and f represent the *peephole* connections. These peephole connections actually denote the contributions of the activation of the memory cell c at time step $t - 1$, i.e. the contribution of c_{t-1} (and not c_t , as the picture may suggest). In other words, the gates i , o and f calculate their activations at time step t (i.e., respectively, i_t , o_t and f_t) also considering the activation of the memory cell c at time step $t - 1$, i.e. c_{t-1} .

The single left-right arrow exiting the memory cell is not a peephole connection and denotes c_t . The little circles containing a \times symbol represent an element-wise multiplication between its inputs. The big circles containing an S -like curve represent the application of a differentiable function (like the sigmoid function) to a weighted sum.

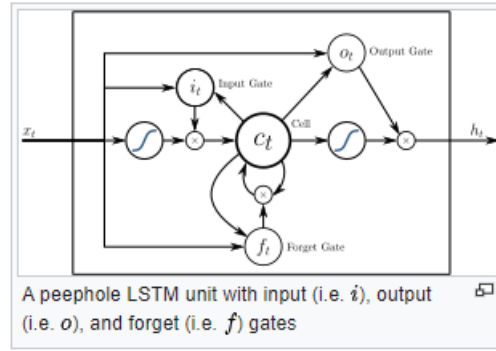

Figure 5: LSTM network

Peephole convolutional LSTM

$$\begin{aligned}
 f_t &= \sigma_g(W_f * x_t + U_f * h_{t-1} + V_f \odot c_{t-1} + b_f) \\
 i_t &= \sigma_g(W_i * x_t + U_i * h_{t-1} + V_i \odot c_{t-1} + b_i) \\
 c_t &= f_t \odot c_{t-1} + i_t \odot \sigma_c(W_c * x_t + U_c * h_{t-1} + b_c) \\
 o_t &= \sigma_g(W_o * x_t + U_o * h_{t-1} + V_o \odot c_t + b_o) \\
 h_t &= o_t \odot \sigma_h(c_t)
 \end{aligned}$$

3 Findings

At the beginning of the research, according to the proposed main steps, the desired data was collected. Therefore, to implement the desired algorithm, using the powerful and reliable Physionet medical library was used. The data set for the collected events in question has 20,956 processes. Basically, the inputs of the algorithm are a history file, which is assumed to be possible to record events sequentially, so that each event refers to an activity and is related to a specific process instance. The table below shows a small part of the history of events.

Table 3: An example of the history of events

RESP	HR	Event	Time	Event ID
30	104	A	17 : 20	100001
18	106	B	17:21	100002
23	92	C	17:22	100003
24	96	D	17:23	100004

By drawing graphs and checking the data, it was found that a number of records contain empty values in the data, so by cleaning and removing them, we tried to make the desired data more suitable for training the network. Therefore, in the following years, it was divided into two parts, training and testing, and training data (70%) and testing data (30%) were considered. In the continuation of the work, due to the sensitivity of LSTM models to the scale of the data, first the data were normalized so that all the data were in the range of zero and one, and for the same purpose, the minimum-maximum normalization method was used.

In the next step, LSTM network model was designed. To run, the model needs to know what input shape to expect. Table 4 shows the various functions and parameters used in the implementation of the model, which are specified based on the results of the research.

After running the model many times (16 times) using different permutations of the number of neurons and batch size and using two activation functions Relu and Tanh, the values related to the average absolute value of error (MAPE) and also the amount The root mean square error (RMSE) was calculated. By examining the results of the model implementation, it was found that the combination of $N = 128$ and Batch size= 64 with Tanh activation function has the best prediction accuracy and the error obtained with the mentioned parameters shows much better results. This information is summarized in Table 5.

Table 4: Various functions and parameters used in the implementation of the model

Mathematical relationship / values	Description	Functions and parameters
$g(z) = \max(0, z)$	Rectifier function	Functions
$g(z) = e^z - e^{-z} / e^z + e - z$	Hyperbolic tangent	
256, 128, 64	Number of neurons (N)	Parameters
128, 64, 32	Batch Size	
Adam	optimizer	
Mean Square Error	Loss	

Table 5: LSTM model execution error by considering the Dropout layer according to Tanh parameters

no	type-value	Title
1	Tanh	Activation function
2	64	batch size
3	128	Nero's number
4	1.39%	MAPE error
5	1.62%	RMSE error

Finally, after completing the previous steps, the model is created and trained. The data considered for the training sample is given to the model and if there is no improvement in the results after 16 repetitions, the training will end. Figure 6 shows the amount of training error and testing error during model training, how it is gradually reduced and minimized.

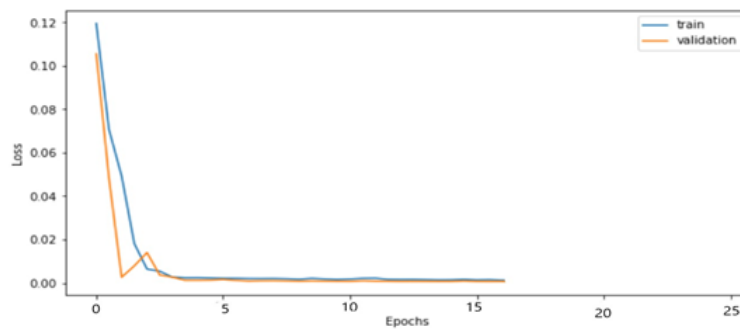

Figure 6: Error reduction process for the training phase in the selected LSTM model

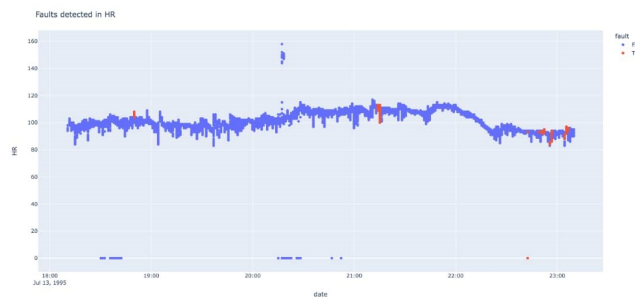

Figure 7: Diagram of correct and incorrect identification of HR abnormalities

In the following, according to the criteria introduced to evaluate the proposed algorithm, the values of these criteria are presented in Table 6. As can be seen in this table, the calculated coefficients fully indicate the efficiency of the proposed algorithm and its high level of accuracy, accuracy, evaluation and recall. Based on these results, the proposed algorithm correctly predicts the outputs of medical devices and sensors with an accuracy equal to 96%. The sensitivity or the accuracy criterion of the proposed algorithm in the positive results is equal to 95%, which confirms its suitability in diagnosing the correct functioning of medical equipment. According to the calculated recall criterion, it can be seen that this algorithm correctly recognizes about 94.5% of negative answers and therefore reduces the probability of errors in the performance of medical equipment and objects under investigation. Finally, the evaluation index also shows that the overall accuracy of this algorithm in tests is equal to 97%.

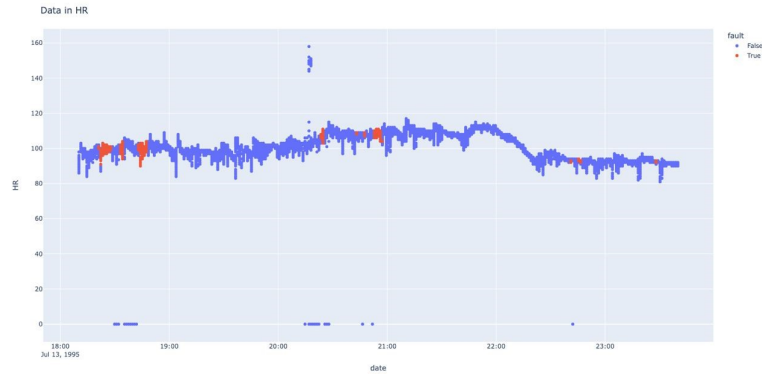

Figure 8: Graph of correct and incorrect HR data

Table 6: Evaluation criteria of the proposed algorithm

Assessment	calling	health	precision	Evaluated criteria
97%	94.5%	95%	96%	Calculated values

4 Conclusions and suggestions

The continuation of all-round progress in the new areas of information technology and their influence on the scientific fields and especially the medical world, the necessity of conducting systematic studies regarding the better understanding of medical objects and equipment and taking measures to increase the accuracy and correctness of the operation of these devices has revealed the importance. has doubled it. In this regard, in order to optimize the performance reliability of diagnostic equipment and wearable sensors and medical equipment, this research was conducted. The results of this study showed that according to the studies conducted in the world, the major challenges in this field are mainly data privacy and security, data management, scalability and upgrade, regulations, interoperability and affordability of IoMT.

After identifying the main challenges of these devices, in order to increase the optimization of the reliability of these devices, by using data from the PhysiNet medical database and using the LSTM method, which is a special type of recurrent neural network (RNN), from A standard architecture with different parameters was used to select the optimal algorithm for determining anomalies. The investigations showed that the LSTM architecture together with the Dropout layer and the Tanh activation function showed better performance and had the lowest average absolute value error (MAPE) as well as the root mean square error (RMSE) in determining the abnormalities of medical equipment. The investigations related to the results of repeating 16 times of optimization also showed that the process of reducing the error in the correct and incorrect identification of anomalies in the training phase by increasing the number of tests has reached its lowest level, which shows the optimality and appropriateness of the proposed algorithm. The accuracy rate of the proposed method is 96%, and the accuracy, recall and evaluation criteria are 95%; 94.5 and 97% have been calculated, which fully shows the suitability of the proposed algorithm in predicting anomalies and, of course, its suitability to increase the assurance of the correct operation of medical equipment and sensors. Therefore, it will be very effective to use it in identifying the possible failures of sensors, the occurrence of critical conditions of patients according to their vital signs, informing and finally helping patients in time.

Since there are other models and algorithms to increase the reliability of medical equipment and solve its major challenges, it is suggested that other methods be used in future studies and by making a comparative comparison, the level of efficiency and optimality. This algorithm should be evaluated in comparison with other scientific and new methods.

References

- [1] T.A. Ahanger, U. Tariq, M. Nusir, A. Aldaej, I. Ullah, and A. Sulman, *A novel IoMT-fog cloud-based healthcare system for monitoring and predicting COVID-19 outspread*, J. Supercomput. **21** (2021), 1–24.
- [2] F. Al-Turjman, H. Zahmatkesh, and L. Mostarda, *Quantifying uncertainty in internet of medical things and big-data services using intelligence and deep Learning*, IEEE Access **7** (2019), 115749–115759.

- [3] K.A. Awan, I.U. Din, A. Almogren, H. Almajed, I. Mohiuddin, and M. Guizani, *NeuroTrust-artificial neural network-based intelligent trust management mechanism for large-scale internet of medical things*, IEEE Internet Things J. **8** (2020), no. 21, 15672–15682.
- [4] N. Bozbogan, M. Tekbas, and S. Gulsecen, *Internet of medical things*, Medical Informatics, Istanbul University Press, 2021, pp. 451–479.
- [5] S.H. Chang, R.D. Chiang, S.J. Wu, and W.T. Chang, *A context-aware interactive M-health system for diabetics*, IT Prof. **18** (2016), no. 3, 14–22.
- [6] M. Cui, S.S. Baek, R.G. Crespo, and R. Premalatha, *Internet of things-based cloud computing platform for analyzing the physical health condition*, Technol. Health Care **29** (2021), no. 6, 1233–1247.
- [7] L.M. Dang, M.J. Piran, D. Han, K. Min, and H. Moon, *A survey on internet of things and cloud computing for healthcare*, Electronics **8** (2019), no. 7, 768.
- [8] M. H. Edalat, R. Azmi, and J. Bagheri Nejad, *Improving the accuracy of forecasting processes in the management of business processes by using LSTM architecture*, Ind. Manag. Perspect. **10** (2019), no. 3, 97–91.
- [9] F. Firouzi, B. Farahani, M. Ibrahim, and K. Chakrabarty, *Keynote Paper: from EDA to IoT eHealth: Promises, Challenges, and Solutions*, IEEE Trans. Comput.-Aided Design. Integr. Circ. Syst. **37** (2018), 2965–2978.
- [10] A. Gatouillat, Y. Badr, B. Massot, and E. Sejdić, *Internet of medical things: A review of recent contributions dealing with cyber-physical systems in medicine*, IEEE Internet Things J. **5** (2018), no. 5, 3810–3822.
- [11] P. Gope and T. Hwang, *BSN-care: A secure IoT-based modern healthcare system using body sensor network*, IEEE Sensors J. **16** (2016), 1368–1376.
- [12] S. Hochreiter and H. Schmidhuber, *Long short-term memory*, Neural Comput. **9** (1997), no. 8, 1735–1780.
- [13] G.J. Joyia, R.M. Liaqat, A. Farooq, and S. Rehman, *Internet of medical things (IOMT): Applications, benefits and future challenges in healthcare domain*, J. Commun. **12** (2017), no. 4, 240–247.
- [14] S. Li, LD. Xu, and S. Zhao, *5G internet of things: A survey*, J. Ind. Inf. Integr. **10** (2018), 1–9.
- [15] H. Magsi, A.H. Sodhro, F.A. Chachar, S.A.K. Abro, G.H. Sodhro, and S. Pirbhulal, *Evolution of 5G in Internet of medical things*, Int. Conf. Comput. Math. Engin. Technol. (iCoMET), Sukkur, 2018, pp. 1–7.
- [16] M. Papaioannou, M. Karageorgou, G. Mantas, V. Sucasas, I. Essop, J. Rodriguez, and D. Lymberopoulos, *A survey on security threats and countermeasures in internet of medical things (IoMT)*, Trans. Emerg. Telecommun. Technol. **33** (2022), no. 6, e4049.
- [17] E. Perrier, *Positive Disruption: Healthcare Ageing and Participation in the Age of Technology*, Sydney, NSW, Australia: The McKell Institute, 2015.
- [18] M. Pham, Y. Mengistu, H. Do, and W. Sheng, *Delivering home healthcare through a cloud-based smart home environment (CoSHE)*, Future Generat Comput Syst. **81** (2018), 129–140.
- [19] Y.A. Qadri, A. Nauman, Y.B. Zikria, A.V. Vasilakos, and S.W. Kim, *The future of healthcare internet of things: A survey of emerging technologies*, IEEE Commun. Surveys Tutor. **22** (2020), 1121–1167.
- [20] A. Rhayem, MBA. Mhiri, K. Drira, S. Tazi, and F. Gargouri, *A semantic-enabled and context-aware monitoring system for the internet of medical things*, Expert Syst. **38** (2021), no. 2, e12629.
- [21] D. Rothman, *Artificial Intelligence By Example*, Packt, Birmingham, 2018.
- [22] O. Salem, A. Guerassimov, and A. Mehaoua, *Anomaly Detection in Medical Wireless Sensor Networks using SVM and Linear Regression Models*, IEEE. Med. **8** (2015), 34–48.
- [23] F. Sarhaddi, I. Azimi, S. Labbaf, H. Niela-Vilén, N. Dutt, A. Axelin, P. Liljeberg, and A.M. Rahmani, *Long-term IoMT-based maternal monitoring: system design and evaluation*, Sensors (Basel). **21** (2021), no. 7, 2281.
- [24] P. Sethi and S. Sarangi, *Internet of things: architectures, protocols, and applications*, J. Electric. Comput. Eng. **2017** (2017), 1–25.
- [25] K. Greff, R.K. Srivastava, J. Koutník, B.R. Steunebrink, and J. Schmidhuber, *LSTM: A Search Space Odyssey*, IEEE Trans. Neural Networks Learn. Syst. **28** (2017), no. 10, 2222–2232.

-
- [26] A.F. Subahi, *Edge-based IoT medical record system: requirements, recommendations and conceptual design*, IEEE Access **7** (2019), 94150–94159.
 - [27] S. Tahir, S.T. Bakhsh, M. Abulkhair, and M.O. Alassafi, *An energy-efficient fog-to-cloud Internet of Medical Things architecture*, Int. J. Distrib. Sensor Networks **15** (2019), 155014771985197.
 - [28] G. Thamilarasu, A. Odesile, and A. Hoang, *An intrusion detection system for internet of medical things*, IEEE Access **8** (2020), 181560–181576.
 - [29] Y. Yin, Y. Zeng, X. Chen, and X. Fan, *The Internet of Things in healthcare: An overview*, J. Ind. Inf. Integr. **1** (2016), 3–13.