

Providing and validating a model for applying critical thinking in accounting education in universities

Mohsen Torkzadeh^a, Bahram Barzegar^{b,*}, Fakhteh Mahini^c

^aPhD Student, Department of Accounting, Bushehr Branch, Islamic Azad University, Bushehr, Iran.

^bAssistant Professor, Department of Accounting, Bushehr Branch, Islamic Azad University, Bushehr, Iran.

^cAssistant Professor, Department of Educational Sciences, Bushehr Branch, Islamic Azad University, Bushehr, Iran.

(Communicated by Madjid Eshaghi Gordji)

Abstract

Today, one of the most important challenges for universities is the teaching of academic disciplines; Including accounting. One of the major challenges of the 21st century is how to educate students who are prepared to face a dynamic and changing society. One of the major challenges of the 21st century is how to educate students who are prepared to face a dynamic and changing society. The accounting learning process should be designed to develop students' ability to think critically. Therefore, providing a model for using critical thinking in accounting education in the universities has been considered by researchers.

In this study, after identifying and classifying the factors affecting accounting education, the obtained model was tested by Structural Equation Modeling. The statistical population of the research in the qualitative part included prominent teachers of accounting and in the quantitative part included teachers and doctoral students of accounting universities. The sample size was 12 in the qualitative part and 286 in the quantitative part.

The results of extracted pattern showed that; The dimensions of causal conditions have a significant effect on axial conditions. Axial phenomenon, Contextual conditions, and intervening conditions have had a significant impact on strategies. Also, strategies have had a significant impact on the consequences. In the end, the main index of Grounded Theory model was favorable fit.

Keywords: Critical thinking, Accounting education, Grounded theory

*Corresponding author

Email addresses: mtorkzadeh@deylamiau.ac.ir (Mohsen Torkzadeh), bbarzegar@iaubushehr.ac.ir (Bahram Barzegar), f.mahini80@iaubushehr.ac.ir (Fakhteh Mahini)

1. Introduction

The management and leadership of society requires critical thinking. The term critical thinking for accountants, such as general accountants, refers to the definition of competence, including cognitive and non-cognitive characteristics, attitudes, and behaviors. Latif et al. ([10]) defined critical thinking as: "A logical answer to a question that certainly cannot be answered and not all information about it may be available. Either academics or stakeholders seeking development critical thinking skills of accounting graduates, so business education should consider critical thinking skills as the main goal to be pursued during the learning or evaluation process. As the importance of critical thinking, Certified Public Accountant always presents some information that need critical thinking: Participants in the Certified Public Accountants test are asked questions that require in-depth analysis and participants will be required to provide solutions to the problems identified ([20]).

Factors that emphasize the importance of critical thinking in accounting education are the new role of accounting work, which is no longer an office work (such as manually counting depreciation, calculating deposits, and preparing accounts receivable for customer approval) ([28]). Such office jobs have now been replaced by computers. Today, accountants are expected to add some values to information and communication and relate it effectively to relevant parties. Accountants are also expected to anticipate and make recommendations when evaluating the institution's system. Cunningham [3] said that critical thinking plays an important role in such activities. Students who think critically, think objectively, and make decisions, evaluate new ideas and techniques effectively, evaluate arguments and claims seriously, and when faced with such processing activities and using of new information, they make rational decisions. Changes in the role of an accountant should be accompanied by changes in the accounting training obtained by future accountants. In addition to enhancing students' intellectual skills, accounting education should have sufficient student software skills, such as communication and interpersonal skills. The accounting learning process should be designed to develop students' ability to think critically, such as integrating global issues into business and their outcomes on accounting ([8]).

In the following sections, first, the theoretical foundations of the research topic and the relationship between the variables are explained; And then the literature review of related studies is presented. In the following, hypotheses and research methods are developed, so that the research population, statistical sample, the variables and method of collecting data are explained. Data analysis and hypothesis testing is implemented with the help of structural equation modeling and model fit study are also presented. In the final part, conclusions and discussion of research findings are discussed.

1.1. Theoretical foundations and literature review

Higher education has undergone major changes since its emergence in Iran until now and in various dimensions, including structure. One of them is that before the Islamic Revolution, it was dominated by a decentralized structure, which has become more centralized after the revolution, and now, the re-orientation towards a decentralized structure manifested itself in various forms, such as the transfer of curriculum planning authority to universities became apparent. As pointed in the research and studies mentioned in the problem statement section and according to the evaluations, Iranian higher education has several challenges such as the negative impact of quality due to quantitative growth, continuity of traditional programs and methods, students' unpreparedness to face with the society problems and needs, and low production of organized knowledge have been faced. To explain the nature of thinking used in any field of study, one must distinguish between the act of thinking (what the mind does) or the "computational level" and the methods it follows (how the mind works) or the

"algorithmic level". Due to the nature of the field of accounting and the view of the professors of this field, they always emphasize on the computational level of thinking (what the mind does) and consider this function as the basis for teaching accounting knowledge and applying it.

Given the issue raised in this study, which is the application of critical thinking in accounting education, questions arise such as; What is critical thinking? Why should critical thinking be addressed? What is the relationship between critical thinking and the curriculum? Is it possible to implement critical thinking in curriculum and classrooms in practice? Based on the definitions of the problem statement section and subsequent sections of the research, including the definition of variables, critical thinking is the attempt to make logical and reassuring assessments to see what we can logically believe and what we can not. In critical thinking, the tools of science and reasoning are used. Critical thinking is mentioned as one of the basic goals of the education system in the world, which is an integral part of any educational system; Because in the process of education, while strengthening the spirit of being critical among educators, the spirit of criticizing and the field of study and research should be created for students. In the following, it will express the weaknesses of the current educational system.

In the previously mentioned researches, the lack of efficiency and effectiveness of accounting training courses for training the graduates required for the profession in today's labor market has been considered. Inevitably, in order to avoid disrupting the service to the institutions related to this field and to meet the needs of the society as a whole, universities and educational centers must make changes in order to adapt their training courses to the mentioned needs which changes with the progress and changes in the world economy. One of the frequent requests of various beneficiaries in the accounting profession to develop advanced critical skills among accounting graduates is to ensure the long-term development of the accounting profession, which is also mentioned in the research of McBride et al. [13]. Other studies also recognize the importance of critical thinking as one of the general skills required by employees, such as the study of Tampon et al. [26]. They also identified a lack of critical thinking skills among accounting graduates.

The findings of various studies on accounting education point to the need to add high-level intellectual skills to accounting education. Kimmel [9] argued that public criticism of accounting education does not succeed in properly developing the skills students need to solve complex and ambiguous problems such as high-level thinking skills. Clients expect professional accountants to evaluate complex systems and information, as well as to detect, anticipate, and take the necessary actions. Accordingly, high-level thinking skills help professional accountants to do these things better.

By applying critical thinking to accounting education, which has been confirmed by numerous researches and materials, it can be seen a change in the "products" offered by the accounting profession to the general public. For example, traditionally, auditing and tax services are the two main products or services offered by professional accountant. Over time, countless other products were introduced to the general public, including a new set of qualifications and skills of accountants. It has been stated that to succeed in public accounting, individuals need to be able to solve a variety of complex problems in unfamiliar situations, understand a deaxialized set of facts, identify and predict problems, and find acceptable solutions. They require learning the required skills and competencies such as critical thinking and creative thinking. With such information, it can be concluded that the traditional teaching approach which focuses heavily on lecturing will generally not be sufficient to develop the skills needed for the workplace. The claim that lectures and textbooks are insufficient was supported by learning theory, primarily because they did not lead to critical thinking and did not encourage students to progress, Howieson's article [6] confirms this point.

Some accounting researchers and professionals in this field have suggested the use of alternative teaching methods such as case studies, practical training and computer training ([12, 5, 15]).

Inadequate training program and weakness of other factors of the educational system is one of the most important reasons for the low level of knowledge and skills of accountants and as a result the quality of financial information. Also, mechanical and incomplete accounting training in problem solving at the university level without emphasis on philosophical insight and transfer of concepts, as well as the quantitative development of this field in universities along with shortcomings in the educational system such as severe shortage of qualified and expert masters, lack of Persian resources, a curriculum tailored to the current socio-economic needs of the country are some causes of these weaknesses.

In this regard, according to the research mentioned above and the evaluations have been made and based on the study of Norawesh, the Secretariat of the Research and Technology Council of the Ministry of Science has announced production and dissemination of basic, applied and developmental knowledge through transformation and revision of educational methods and programs and emphasis on fostering creativity and entrepreneurship according to the current needs of society as the goals and policies of its research units. Consequently, the important goal of the country's higher education system is to respond to the needs of the labor market and society and users of the services of specialized personnel raised from this educational system, to review and adapt educational programs to train students who have entrepreneurial potential based on the current economic and technological conditions. For the above reasons, it is necessary to change the curriculum of the accounting undergraduate course by implementing critical thinking in it, so that it can increase the ability of analysis and thinking in accounting graduates and consequently increase the quality of accounting information requested by Iranian beneficiaries(stakeholders) Since no independent study in the field of accounting has been done on the applying critical thinking in the components of the undergraduate course, the present study has sought to do this in two qualitative and quantitative stages. It is hoped that the results of this study will be useful for those in charge of educational planning, professors and students of accounting in order to improve the services provided by the accounting community.

1.2. Research hypotheses

Based on the theoretical foundations and literature review of the research, the following hypotheses have been developed and tested:

- Causal conditions have a significant effect on axial conditions.
- Contextual conditions have a significant effect on strategies.
- Intervening conditions have a significant effect on strategies.
- Axial conditions have a significant effect on strategies.
- Strategies have a significant effect on results / outcomes.
- The mediating role of axial conditions has a significant effect on the relationship between causal conditions and strategies.
- The mediating role of strategies has a significant effect on the relationship between contextual conditions and outcome/ results.
- The mediating role of strategies has a significant effect on the relationship between intervening conditions and outcomes.
- The mediating role of strategies has a significant effect on the relationship between axial conditions and outcomes.

2. Research methodology

At this stage, researchers have tried to analyze the data that collected through a researcher-made questionnaire in the statistical population at both descriptive and inferential levels. The statistical population of the research in the qualitative part included prominent professors of accounting and in the quantitative part included professors and doctoral students of accounting universities. The sample size was 12 people in the qualitative stage and 286 people in the quantitative stage. In the qualitative stage, the sample members were considered by purposive sampling method based on the saturation principle, and in the quantitative stage, the sampling method based on the principles of determining the sample size was used in structural equations modeling. Therefore, in order to examine the motivations and inclinations of the respondents to each question, the questionnaire was analyzed separately for the dimensions of the questions related to each component based on the Chi-Square Fit Test based on the mean, middle and mode of each question. Also, in order to determine the normality or abnormality of the variables, all the main variables of the research (dimensions and components) were examined in terms of mean, standard deviation, skewness and elongation.

On the other hand, at the inferential level, first the reliability of the tool (dimensions and components) was calculated and the validity of the questionnaire was determined. Then, with the help of Factor Analysis of items related to each component, the components related to each dimension were studied in terms of Load Factor and the fitting status of models related to each dimension was evaluated. Then, the final model based on the proposed model was drawn and its fit was analyzed and then the research questions and hypotheses based on the final model were answered.

2.1. Research variables

As mentioned earlier, the main purpose of this study is to present and validate the model of applying critical thinking in accounting education in universities based on the data based model, according to which the research variables are:

Causal factors: In this study, causal factors are defined as the main and independent variables of the research with multiple dimensions including components of curriculum and used resources, educational facilities and equipment, personality and scientific characteristics of the professors, professors' methods in conveying the educational concepts, students' characteristics, needs and interests, organizational conditions, development of a strategic plan for critical thinking, encouragement and motivation and personality and inner characteristics of the student is.

Axial conditions: In this research, the axial conditions are defined as mediating variables and include components of critical thinking training in accounting, upgrading the educational system, empowering students, developing critical thinking, student characteristics, knowledge oriented professors, professors' approach.

Contextual(underlying) conditions: In this research, the Contextual conditions are defined as main and independent variables of the research with components of Student participation in learning, students' attention to critical thinking, research in teaching methods, individual factors, organizational factors, student needs and extracurricular factors.

Interventional factors: In this study, interventional factors are defined as the main and independent variables of the research with components of environmental conditions, relationship between university and profession, human resources, executive platforms and human resources platforms.

Strategies: In this research, strategic conditions are defined as the main and independent variables of the research with components of variety in teaching methods according to the objectives, attention to the practical dimensions of teaching methods, develop a management strategy, effective and timely evaluation of students, facilitator mechanisms, professors preparation, teaching strategy and the existence of students with minds full of questions.

Outcomes: In this research, the outcomes are defined as the main and dependent variables with multiple dimensions including components of students as social capital, greater convergence of profession and university, innovative approach to teaching and learning, change of thinking and attitude of professors, social responsibility, critical discourse modeling and preparation for better attraction of graduate students.

To show the relationship between research variables and testing hypotheses, the following conceptual model is presented:

1. Conceptual model and relationship between research variables

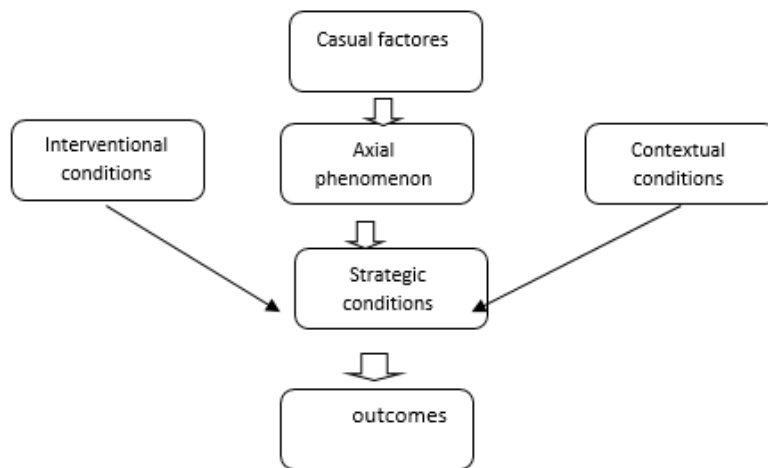

Figure 1: Conceptual model and relationship between research variables

3. Research findings

Tools Reliability: Cronbach’s alpha test was used to determine the reliability of the tools (questionnaire) (Table 1). According to the dimensions and components of the questionnaire, Cronbach’s alpha values for all variables were higher than 0.7, which indicates the high validity of the tools.

Table 1: Dimension’s Reliability of causal conditions and its components

Cronbach’s Alpha	Questions	Variables
0/96	1-39	Casual conditions
0/79	1-4	Curriculum and used resources
0/77	5-7	Educational equipment and facilities
0/92	8-18	Professors’ personality and scientific characters
0/75	19-21	Method of professors conveying concepts
0/84	22-25	Students’ characters, needs and interests
0/79	26-28	Organizational conditions
0/71	29-30	Development of strategic program of critical thinking
0/82	31-33	Motivation and encouragement
0/87	34-39	Students’ personality and inner characteristics

0/96	40-78	Axial conditions
0/84	40-44	critical thinking training in accounting
0/80	45-48	upgrading the educational system
0/89	49-56	empowering students
0/85	57-60	developing critical thinking
0/84	61-65	student characteristics
0/86	66-69	knowledge oriented professors
0/89	70-78	professors' approach
0/94	79-108	Contextual conditions
0/83	79-82	Student participation in learning
0/85	83-85	students' attention to critical thinking
0/70	86-87	research in teaching methods
0/87	88-95	individual factors
0/82	96-99	organizational factors
0/86	100-106	student needs
0/70	107-108	extracurricular factors.
0/92	109-128	Interventional factors
0/87	109-113	environmental conditions
0/84	114-117	relationship between university and profession
0/81	118-121	human resources
0/84	122-125	executive platforms
0/84	126-128	and human resources platforms
0/96	129-170	Strategies
0/92	129-142	variety in teaching methods according to the objectives
0/84	143-145	attention to the practical dimensions of teaching methods
0/90	146-151	develop a management strategy
0/86	152-156	effective and timely evaluation of students
0/83	157-159	facilitator mechanisms
0/85	160-162	professors preparation
0/81	163-165	teaching strategy
0/87	166-170	the existence of students with minds full of questions
0/96	171-204	Outcomes
0/83	171-174	students as social capital
0/85	175-178	greater convergence of profession and university
0/83	179-182	innovative approach to teaching and learning
0/84	183-187	change of thinking and attitude of professors
0/89	188-193	social responsibility
0/84	193-196	critical discourse modeling
0/91	197-204	preparation for better attraction of graduate students
0/99	1-204	Total of questionnaire

3.1. Confirmatory factor analysis and model fit

In order to evaluate the proposed model, the path analysis method in the structural equation modeling process was used with the help of LISREL 8.8 software, the findings are presented below. In order to evaluate the fit of the model, chi-square Indices, chi-square ratio of 2 to degree of freedom, Goodness of Fit Index (GIF), and Root Mean Square Error (RMSEA) of approximation were used. If

the chi-square is not statistically significant, it indicates that it fits very well, but since this index is often in samples larger than 100, is significant, it is not a suitable index for model fit. If the ratio of chi-square to degree of freedom is less than 3, it shows a very good fit. chi-square quantity is highly dependent on the sample size, and the large sample increases the quantity of chi-square more, so that it cannot be attributed to the inaccuracy of the model([25]).

GFI and AGFI criteria represent a measure of the relative amount of variances and covariance that are explained by the model. Both of these criteria vary between zero and one; the closer they are to number one, the better the fit of the model with the observed data.

If the CFI, AGFI, GFI indices are greater than 0.90 and the RMSEA index is less than 0.08, it indicates the optimal fit of the model. Also, the minimum Average Variance Explained(AVE) in LISREL is 0.35 and the combined reliability is at least 0.5. If there is a minimum average variance explained and combined reliability, it can be said that the model has convergent construct validity. Also, in the field of model fit and in order to optimally fit the model and confirm the above-mentioned statistical indicators in each model, questions and components with a load factor of less than 0.3 can eliminate and improve the model fit desirably ([11]). In order to evaluate the proposed model, factor analysis method was used, the findings are presented in the following.

3.2. Factor analysis of components

In this section, the confirmatory factor analysis of all components that are 43 ones (causal conditions, 9 components; Axial conditions, 7 components; contextual conditions, 7 components; interventional factors, 5 components; strategic conditions, 8 components; outcomes, 7 components) with 204 questions, were examined separately. Cases with a load factor of less than 0.3 were excluded. Here, as an example, the results of confirmatory factor analysis of questions 1 to 4 related to the curriculum component and used resources are presented in Figure 2. The load factor of the third question was less than 0.3, so it was removed. Also, the goodness of fit indicators are shown in Table 2 and the structure validity is shown in Table 3.

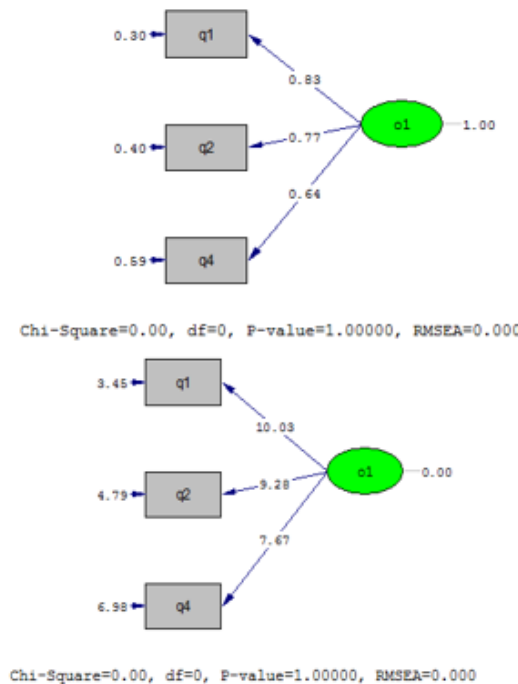

Figure 2: Standard coefficients and t statistic values of component of curriculum and used resources

Table 2: Goodness of fit indicators of structure model of component of curriculum and used resources

status	Calculated value	value	name	No
desirable	00/0	< 3	Ratio of chi-square to freedom degree	1
desirable	00/1	> 0.05	P value	2
desirable	000/0	< 0.08	RMSEA	3
desirable	00/1	> 90/0	NNFI	4
desirable	00/1	> 90/0	NFI	5
desirable	00/1	> 90/0	CFI	6
desirable	00/1	> 90/0	AGFI	7
desirable	00/1	> 90/0	GFI	8

According to Table 2, for CFI, AGFI and GFI index, the values are 1.00, 1.00 and 1.00, respectively. The value of the Comparative Fit Index(CFI), the Adjusted Goodness-Fit Index(AGFI) and the Root of the Estimation of Variance of the Approximation Error is higher than 0.9, and it shows that the goodness-of-fit of the model is higher with the observed data. Also, the value of RMSEA index is equal to 0.000 which indicates the optimal fit of the model. The ratio of chi-square to the degree of freedom is 0.00, which should be less than 3 and is desirable.

Table 3: Results of structural validity examination- convergent

Significance of convergent structure validity	Combined reliability	AVE	Significance of load factor	load factor	items
√	0/56	0/74	√	0/83	Item1
			√	0/77	Item2
			√	0/64	Item4

According to Table 3, the load factor of the component items of curriculum and the used resources are between 0.64 and 0.83, and all of them are higher than 0.3. On the other hand, the average value of variance extracted based on load factor is 0.56. This means that the items related to the studied component explain 56% of the variance of the curriculum component and the used resources component and is higher than 0.35. The greater the amount of variance explained, the greater the consistency of the items in measuring the relevant variable. On the other hand, the value of combined reliability is 0.74 and should be greater than 0.5, therefore, the existence of convergent -construct validity for the curriculum and used resources component is confirmed.

3.3. Optimal model fit

According to the factor analysis performed on the components and dimensions and the elimination of questions whose load factor was less than 0.30, it was tried to draw a total fit model and to determine the direct and indirect effects between the variables, and the research questions and hypotheses were examined. The final research model is presented in Figures 3 and 4.

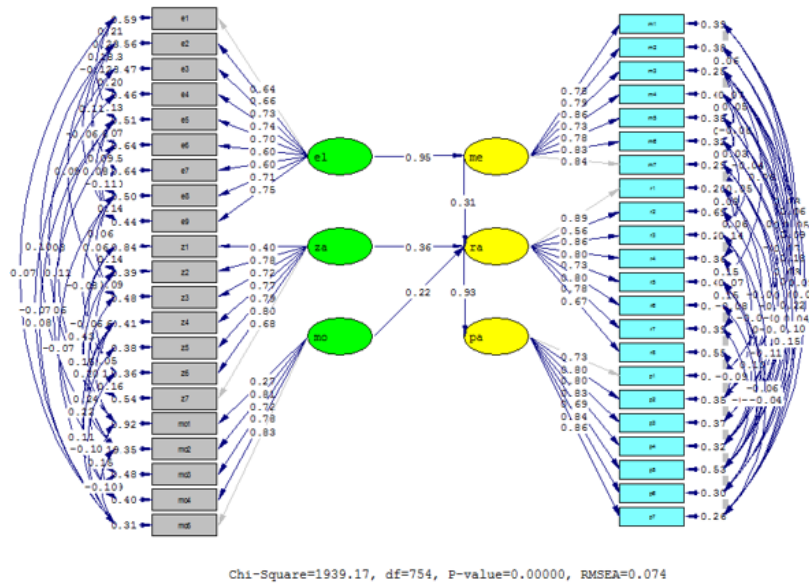

Figure 3: Path standard coefficients

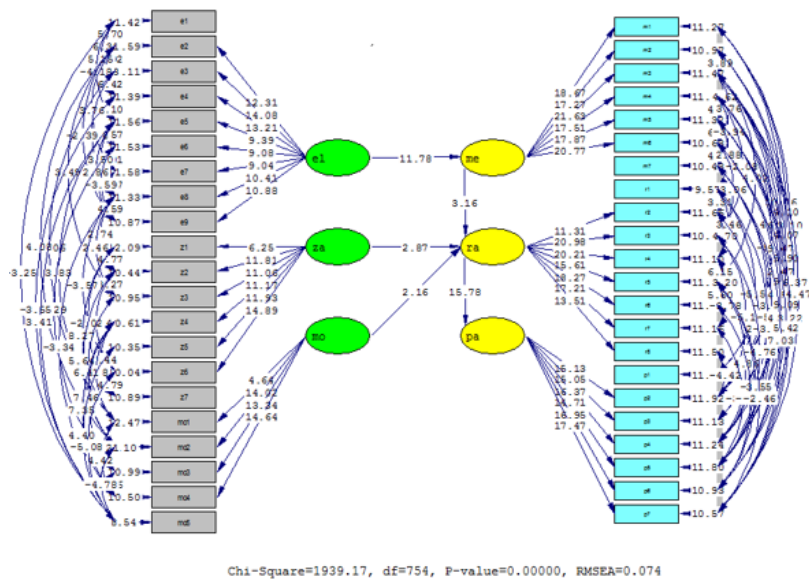

Figure 4: t-statistic value of final model

For CFI, AGFI and GFI index, the values are 0.98, 0.90 and 0.96, respectively. The value of the comparative fit index and the root of the estimation variance of the approximation error (GFI) are higher than 0.9 and indicate that the goodness of the model fits is higher with the observed data. The adjusted goodness fit index was 0.90, which is equal to 0.9. Also, the value of RMSEA index is equal to 0.074, which indicates the optimal fit of the model. The ratio of chi-square to the degree of freedom is 2.57, which should be less than 3 and is desirable.

According to Table 5, the model dimension loads are between 0.65 and 0.95 and all are higher than 0.3. On the other hand, the average value of variance extracted based on load factor is 0.66. This means that the model dimensions explain 66% of the variance of the studied model. The greater the amount of variance explained, the greater the consistency of the items in measuring the relevant variable. On the other hand, the combined reliability value is 0.81 and should be greater than 0.5,

Table 4: Goodness indices of model fit of final structural model

Calculated value	value	name	No
2.57	< 3	Ratio of chi-square to freedom degree	1
000/0	> 0.05	P value	2
074/0	< 0.08	RMSEA	3
97/0	> 0.90	NNFI	4
98/0	> 0.90	NFI	5
98/0	> 0.90	CFI	6
90/0	> 0.90	AGFI	7
96/0	> 0.90	GFI	8

source: research findings

Table 5: Results of structural validity- convergent validity for research conceptual model

Converged structure validity	Combined reliability	AVE	Significance of load factor	Load factor	dimension
√	0/81	0/66	√	0/83	Casual conditions
			√	0/92	Axial phenomenon
			√	0/95	Contextual conditions
			√	0/77	Intervening conditions
			√	0/74	strategies
			√	0/65	outcomes

source: research findings

therefore, the existence of convergent-construct validity for the proposed model is confirmed. Now, according to the optimal fit of the model, the results of path analysis are based on tables 6 and 7 in order to answer the hypotheses:

Table 6: Path analysis- estimation of direct effect coefficients

T	standard error of estimation	Standardized parameter	Variables
11.78	0.08	0.96**	Casual conditions on axial phenomenon
3.16	0.10	0.31**	axial conditions on strategies
2.87	0.14	2.87	contextual conditions on strategies
2.16	0.20	0.22*	intervening conditions on strategies
16.78	0.05	0.93**	Effect of strategies on outcomes

source: Research findings(**P < 0.01, * P < 0.05)

Hypothesis 1: Causal conditions have a significant effect on axial conditions.

According to the information in the above table, the effect of the components of causal conditions on the axial phenomenon is equal to 0.96, according to the value of t (11.78) which is significant at the level of 0.01. Therefore, the first hypothesis of the research is confirmed that causal conditions have a positive and significant effect on the axial conditions.

Hypothesis 2: Contextual conditions have a significant effect on strategies.

According to the information in the above table, the effect of the components of the Contextual conditions on the strategies is equal to 0.36, according to the value of t (2.87) which is significant at the level of 0.01. Therefore, the second hypothesis of the research is confirmed that the contextual conditions have a positive and significant effect on strategies.

Hypothesis 3: Intervening conditions have a significant effect on strategies.

According to the information in the table above, the effect of the components of the interventionist conditions on the strategies is equal to 0.22, according to the value of t (2.16) which is significant at the level of 0.05. Therefore, the third hypothesis of the research is confirmed that the intervening conditions have a positive and significant effect on strategies.

Hypothesis 4: Axial conditions have a significant effect on strategies.

According to the information in the table above, the effect of axial conditions on strategy is equal to 0.31, according to the value of t (3.16) which is significant at the level of 0.01. Therefore, the fourth hypothesis of the research is confirmed that the axial conditions have a positive and significant effect on strategies.

Hypothesis 5: Strategies have a significant effect on outcomes.

According to the information in the table above, the effect of strategy components on results / outcomes is equal to 0.93, according to the value of t (16.78) which is significant at the level of 0.01. Therefore, the fifth hypothesis of the research is confirmed that strategies have a positive and significant effect on results / outcomes.

3.4. Indirect effect path analysis

The following table shows the indirect effect coefficients:

Table 7: Path analysis – estimation of the indirect effect coefficients

T	standard error of estimation	Standardized parameter	propositions
3.08	0.10	0.32**	The effect of casual conditions on strategies with mediating role of axial condition
2.87	0.11	0.33**	The effect of contextual conditions on outcomes with mediating role of strategies
2.16	0.07	0.16*	The effect of intervening conditions on outcomes with mediating role of strategies
3.07	0.09	0.26**	intervening conditions on The effect of axial phenomenon on outcomes with mediating role of strategies

source: Research findings(P < 0.05, P < 0.01)

Hypothesis 6: The mediating role of axial conditions has a significant effect on the relationship between causal conditions and strategies.

In investigating the indirect effect of causal conditions on strategy, with the mediating role of axial conditions, the value of t was equal to 3.08, which is more than 1.96 and is significant at the level of 0.01. Therefore, it can be said that causal conditions on strategies with mediating role of Axial conditions has a significant effect.

Hypothesis 7: The mediating role of strategies has a significant effect on the relationship between contextual conditions and outcomes.

In investigating the indirect effect of contextual conditions on outcomes, with the mediating role of strategies, the value of t was equal to 2.87, which is more than 1.96 and is significant at the level of 0.01. Therefore, it can be said that the contextual conditions on the results/consequences have a significant relationship with the mediating role of strategies.

Hypothesis 8: The mediating role of strategies has a significant effect on the relationship between intervening conditions and outcomes.

In investigating the indirect effect of intervening conditions on outcomes, with the mediating role of strategies, a value of t was equal to 2.16, which is more than 1.96 and is significant at the level of 0.05. Therefore, it can be said that intervening conditions have a significant effect on outcomes with the mediating role of strategies.

Hypothesis 9: The mediating role of strategies has a significant effect on the relationship between axial conditions and outcomes.

In investigating the indirect effect of axial conditions on results/outcomes, with the mediating role of strategies, the value of t was equal to 3.07, which is more than 1.96 and is significant at the level of 0.01. Therefore, it can be said that axial conditions on results/outcomes have a significant impact on the mediating role of strategies.

4. Discussion and conclusion

Research over the past decade has shown that accounting graduates have no critical thinking. Researchers have concluded that accounting professors emphasize the maintaining of accounting principles without addressing their theoretical concepts. The role of cause and effect of critical thinking in the position of cause has been the motivation of critical studies in accounting education and finding weaknesses and inadequacies in education. The application and implementation of proposed solutions has emerged the critical thinking in the position of effect. The causal relationship of critical thinking and determining the relations between accounting knowledge and critical thinking is discussed in this study. Therefore, the purpose of this study is to develop a model for applying critical thinking in accounting education.

The analysis of the results of the hypotheses shows that components such as: curriculum and used resources, educational facilities and equipment, personality and scientific characteristics of the professors, the method of conveying the concepts of professors, students' characteristics, needs and interests, organizational conditions, developing a strategic plan for critical thinking, encouragement and motivation, the personality and inner characteristics of students should be strengthened to be able to succeed in teaching and developing critical thinking, upgrading the educational system, empowering students, and the knowledge-based approach of professors. By strengthening and supporting the axial and contextual conditions (student participation in learning, students' attention to critical thinking, research in teaching methods, etc.); and also, paying attention to the interventional factors (environmental conditions, human resources, executive platforms and human resources platforms); The realization of strategic conditions (diversity in teaching methods, development of management strategy, facilitator mechanisms, teaching strategy, etc.) can be facilitated. The results of these approaches and activities lead to the acceptance of students as social capital, greater convergence of profession and university, innovative teaching and learning approach, change of professors' thinking and orientation, social responsibility, critical discourse modeling and preparation for better attraction of graduate students. The results of the research are consistent with the results of Rezaei's research ([21]) entitled "Quality of education and validation in business and accounting colleges" based on

focusing on strategy and its preparation and development, attention to the business environment and communication with companies and practical training, proper resource management, proper combination of theories, research and appropriate practical procedures in training and observance of ethics for validation of accounting training. Also, the mentioned results are consistent with the research of Salehi et al. ([23]) entitled "Challenges of accounting education in Iran from the perspective of professionals and academic authorities" which identified the factors such as "insufficient attention to students' familiarity with new tools of information technology", "lack of adequate attention to educate the legal requirements of the practice world and "students' lack of sufficient practical skills" as the main challenges facing accounting education. The result of Pak Mehr et al.'s ([18]) research is that there is a significant relationship between "teaching quality and students' critical thinking" and it is in line with the results of the present study. In the research of Baghumian and Rahimi Baghi ([1]) entitled "Obstacles to the development of accounting education in Iran", insufficient mastery of accounting professors and students in information technology is the most important factor that is considered as an obstacle to the development of accounting education and it has been considered in the present study. The results of research by Pourheidari and Rajizadeh ([19]), Mojtahedzadeh et al. ([14]), Tew ([27]), Dzurainin, et al. ([4]), Wilkin ([30]) and Mohammad and Soleiman ([15]) emphasize on the need to learn and develop knowledge and skills required for the accounting profession, including analytical skills such as critical thinking skills, which is consistent with the main theme of the present study, which is to increase the critical thinking skills of accounting students.

Also, the results of the present study confirm the research of Roodposhti et al. entitled "Determining the priorities and educational needs of the content of accounting courses from the perspective of students, university professors and professionals and providing an effective model" which emphasizes on the need for necessary changes in the content of specialized courses, the number of units of specialized courses and the most effective method of teaching accounting in order to develop a framework for planning the field of accounting in different stages. Chen ([2]), Smith et al. ([24]), Kimmel [9] and Norawesh ([17]) researches emphasize the need to make changes in the accounting curriculum. In this regard, in the article by Watty et al. ([29]), he has identified the use of qualitative data obtained from interviews with accounting instructors, and the use of new technologies; it showed that timely insight is effective in higher education institutions, especially accounting academics, in the 21st century. Hyytinen's research ([7]) investigates the issues such as students' skills and tendencies to think critically, students' ability to adapt thinking and their flexibility in performance, the nature of the knowledge which students relate, the knowledge that students have in problem-solving situations and the way students process knowledge and identify methodological challenges in evaluating critical thinking that are consistent with the results of this study.

The results also showed; The mediating role of axial conditions on the impact of causal factors on strategic conditions; The mediating role of strategic conditions on the impact of axial conditions on outcomes; The mediating role of strategic conditions on the impact of axial conditions on outcomes; The mediating role of strategic conditions on the impact of axial conditions on outcomes; it's positive. This means that according to the model presented and approved; All factors play an important role in the causes and effects.

According to the obtained results, some suggestions can be made as follows:

4.1. *Practical suggestions*

1. Considering the necessity of teaching critical thinking and its effect on the performance of accountants and auditors, it is necessary to develop a curriculum for different educational levels.

2. Curriculum planners, who are the main custodians of curriculum development can use the results of this research to get acquainted with the issues and general outlines of teaching critical thinking and try to determine the appropriate goals, content, method and evaluation.
3. Using the results of this research, training courses should be held to raise the awareness and familiarity of professors with the category of critical thinking, so that this will eventually lead to better learning for students.
4. In the design stage of the critical thinking training program for content regulation, the method of organizing separate topics should be used that its purpose is to acquire knowledge and ideas in the subject being taught and to develop and cultivate mental discipline through the study of that subject.

4.2. Research suggestions

Investigating the interactive relationship between the paradigmatic model of the foundation data developed in the present study using the method of interpretive structural equations.

References

- [1] R. Baghumian and A. Rahimi Baghi, *Obstacles to the development of accounting education in Iran*, Quarterly Journal of Experimental Studies in Financial Accounting, 10 (35) (2013) 91-69.
- [2] Y. Chen, *Learning to learn: The impact of strategy training*, ELT journal, 61(1) (2007) 20-29.
- [3] B. M. Cunningham, *Developing critical thinking in accounting education*, London, Routledge, (2014) 399-420.
- [4] A. C. Dzurainin, J. R. Jones and R. M. Olvera, *Infusing data analytics into the accounting curriculum: A framework and insights from faculty*, Journal of Accounting Education, 43 (2018) 24-39.
- [5] K. Hogarth and B. Luke, *Transitioning from dependent to more independent learners: Using video tutorials as a means of helping students help themselves*, In *Proceedings of the 2010 Accounting and Finance Association of Australia and New Zealand (AFAANZ) Conference*, Accounting and Finance Association of Australia and New Zealand (AFAANZ), (2010) 1-21.
- [6] B. Howieson, *Accounting practice in the new millennium: is accounting education ready to meet the challenge?*, The British Accounting Review, 35(2) (2003), 69-103.
- [7] H. Hyttinen, *Looking Beyond the Obvious; Theoretical, Empirical and Methodological Insights into Critical Thinking*, Institute of Behavioural Sciences. Helsinki: University of Helsinki, (2015) 260.
- [8] D. T. Irafahmi, D. M. R. Nuris, F. Zahroh and P. M. Nagari, *Critical Thinking in Accounting Textbooks*, Journal of Education and Learning (EduLearn), 12(1) (2018) 21-29.
- [9] P. Kimmel, *A framework for incorporating critical thinking into accounting education*, Journal of accounting education, 13(3) (1995) 299-318.
- [10] N. E. A. Latif, F. M. Yusuf, N. M. Tarmezi, S. Z. Rosly and Z. N. Zainuddin, *The Application of Critical Thinking in Accounting Education: A Literature Review*, International Journal of Higher Education, 8(3) (2019) 57-62.
- [11] S. M. Leach, J. C. Immekus, B. F. French and B. Hand, *The factorial validity of the Cornell Critical Thinking Tests: A multi-analytic approach*, Thinking Skills and Creativity, 37 (2020) 100676.
- [12] L.M. Ling and N. H. A. Nawawi, *Integrating ICT skills and tax software in tax education: A survey of Malaysian tax practitioners' perspectives*, Campus-Wide Information Systems, 27(5) (2010) 303-317.
- [13] H. McBride, S. Hannon and B. Burns, *Developing Critical Thinking Abilities in Business and Accounting Graduates*, The Irish Accounting Review, 12(2) (2005) 23-45.
- [14] V. Mojtahedzadeh, S.H. Alavi Tabari and F. Moradi Pour, *Required Knowledge and Skills for Undergraduate Accounting Graduates from the Perspectives of University Professors, Professionals and Accounting Students (Case Study: West Azerbaijan Province)*, Quarterly Journal of Accounting Knowledge, 1 (1) (2010) 87-73.
- [15] R. Muhamad and N. A. Sulaiman, *Higher-Order or Critical Thinking Skills: Does Accounting Education Need Reforms?*, Asian Journal of Accounting Perspectives, 6(1) (2013) 12-20.
- [16] I. Norawesh, *Examining the process of changing the curriculum and proposing an updated curriculum for the undergraduate course in accounting*, Quarterly Journal of Accounting and Auditing Reviews, 10 (32) (2003) 42-21.
- [17] I. Norawesh, *Towards a Future for the Accounting Infrastructure of Developing Countries*, Quarterly Journal of Accounting and Auditing Reviews, 8 (2) (1999) 84-50.

- [18] H. Pak Mehr, H. Jafari Thani, M. Saeedi Rezvani and H. Kareshki, *The role of professors' teaching quality and its components in the development of students' critical thinking opportunities and challenges of the curriculum in higher education*, *Bi-Quarterly Journal of Educational Psychology*, 9 (16) (2013) 38-17.
- [19] O. Pourheidari and S. Rajizadeh, *Investigating the knowledge and skills required by the accounting profession and its distance from current accounting training in Iran*, *Financial Accounting Quarterly*, 3 (11) (2012) 71-51.
- [20] N. Raimee and N. M. Radzi, *Exploring the Needed Soft Skills amongst Accounting Students*, *Asian Journal of Accounting and Finance*, 2(2) (2020) 14-27.
- [21] M. Rezaei, *Quality of Education and Validation in Business and Accounting college*, *Quarterly Journal of Accounting Research*, 7 (26) (2017) 150-131.
- [22] F. Roodpashti Rahnamay, H. Vakilifard and S.M. Raeeszadeh, *Determining the priorities and educational needs of the content of accounting courses from the perspective of students, university professors, professionals and providing an effective model*, *Quarterly Journal of Accounting and Auditing Research*, 1 (4) (2009) 97-78.
- [23] M. Salehi, F. Nasirzadeh and V. Rostami, *Challenges of Accounting Education in Iran from the Perspective of Professionals and Academic Authorities*, *Auditing Knowledge Quarterly*, 8 (54) (2013) 86-67.
- [24] T. B. Smith, M. G. Constantine, T. W. Dunn, J. M. Dinehart and J. A. Montoya, *Multicultural education in the mental health professions: A meta-analytic review*, *Journal of counseling psychology*, 53(1) (2006) 132-145.
- [25] L. Sun, L. Hu, W. Yang, D. Zhou, and X. Wang, *STEM learning attitude predicts computational thinking skills among primary school students*, *Journal of Computer Assisted Learning*, 37(2) (2021) 346-358.
- [26] G. P. Tampon, O. M. Nuntilde, A. C. and Diesmos, *Bioacoustic analysis of advertisement calls of two ground-frogs of the genus *Platymantis* in Mount, Magdiwata, San Francisco, Agusan del Sur, Philippines*, *International Journal of Biodiversity and Conservation*, 4(7) (2012) 277-286.
- [27] E. W. Tew, *Critical thinking in the context of group learning: A qualitative Study of postgraduate accounting and finance students' perceptions (Doctoral dissertation)*. Bristol: University of the West of England, (2020).
- [28] R. Walstra, S. Harrington and A. and Drougas, *Developing financial competencies within the business curriculum: a deferred tax assignment*, *Journal of Finance and Accountancy*, 15(1) (2014) 22-41.
- [29] K. Watty, J. McKay and L. Ngo, *Innovators or inhibitors? Accounting faculty resistance to new educational technologies in higher education*, *Journal of Accounting Education*, 36 (2016) 1-15.
- [30] C.L. Wilkin, *Enhancing Critical Thinking: Accounting Students' Perceptions*, *Education + Training*, 59(1) (2017) 15-30.